

IMPREZA

2011



SUBARU



Always a Subaru.

The difference in driving a Subaru is the confidence you feel. A deep sense of contentment that comes from a consistent balance of exciting performance, ingenious design and reassuring safety rarely found in such harmony. It starts with our exclusive engineering – Subaru symmetrical full-time All-Wheel Drive for greater control and the SUBARU BOXER engine for greater balance. And it extends to every component of your vehicle to create a thoroughly incredible driving experience that simply cannot be ignored.



Always

moving at the speed of you.



Drive the sporty 2011 Subaru Impreza 4-door or the fierce 5-door and you immediately feel this confidence in your hands. The steering is direct, the handling is sublime, and the traction and grip are palpable, all adding up to an undeniably fun-to-drive vehicle. But the feeling doesn't end there. There's also the confidence in knowing you're driving a vehicle that offers excellent value, impressive fuel efficiency, satisfying convenience features and class-leading safety systems. The Impreza is the smart choice that rewards you every day, no matter where you're headed or what you've planned.



2.5i Sport Package

a Subaru Impreza.



Always sporty, stylish and fun to drive.

Always filled with smart ideas.

Always safe and sound.



Always ready for your next turn.

The unique engineering of the Subaru Impreza creates performance that is exhilarating and responsive, confident and in control. With so much capability on tap, you'll wonder how you ever got by driving anything else.



Stay connected.

Subaru symmetrical full-time All-Wheel Drive

Symmetry gives you balance. Balance gives you control. This is why Subaru has spent nearly 40 years developing and perfecting the Subaru symmetrical full-time AWD system. Enhanced by the SUBARU BOXER engine for an almost perfectly symmetrical layout, it maximizes the power delivery with exceptional traction and generates balance and stability for better control in all conditions. More control inspires more confidence behind the wheel and a more gratifying driving experience overall.

DYNAMIC PERFORMANCE

Exceptional traction, courtesy of Subaru symmetrical full-time AWD, makes acceleration feel immediate and exhilarating. Combined with its symmetrical drivetrain layout, the Impreza is able to deliver responsive handling, stability in the corners and a unique feeling of control at all times.

CONSTANT CONTACT

The more your tires are engaged with the road, the more control you have. This is why power is routed to all four wheels while the vehicle is in motion, so the AWD system doesn't have to react to potential hazards like puddles, bumps or potholes in the road. Instead, the system is able to keep the tires connected to the road as closely as possible at all times.

AGILITY IN AN EMERGENCY

In poor weather, or in the precious seconds it takes to react to a sudden situation, the Subaru symmetrical full-time AWD system – which is almost perfectly balanced side-to-side – provides the stability, agility and traction that help you steer away from danger.



Stay balanced.

SUBARU BOXER engine

Few other vehicles drive with the fun and eagerness of the Subaru Impreza, so it's little surprise that this result has been achieved by an innovative design that gives it a clear edge over the competition. The horizontally opposed configuration of the SUBARU BOXER engine places the pistons 180 degrees apart for a lower, flatter profile than other engine types. This gives the engine, and therefore the overall vehicle, a lower centre of gravity and better sense of balance. Furthermore, the pistons' opposing movements inherently counteract each other, naturally helping to reduce vibration and boost driving comfort.

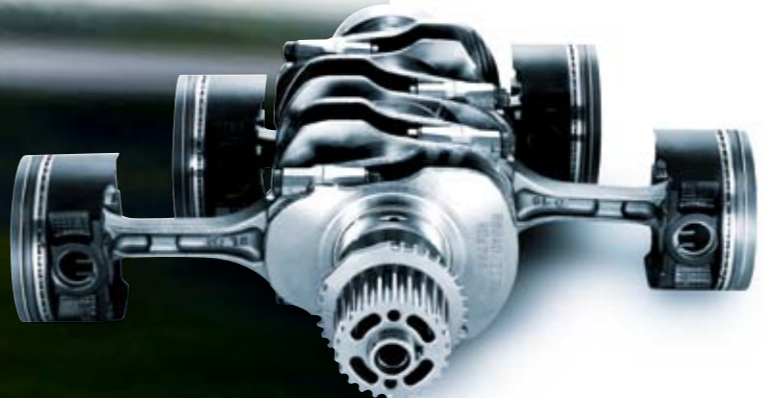

INCREASED STABILITY

Because the engine block has a flatter profile and sits lower in the chassis, the vehicle is more balanced and resistant to side-to-side motion than other engine configurations.

SMOOTH POWER

At any rpm the engine delivers immediate, responsive power that comes on smooth. This occurs because the pistons lay flat and work against each other to reduce vibration, making the ride as easy and comfortable as it is exciting.

LONG-LASTING PERFORMANCE

The engine's flat design is inherently rigid and self-balancing, generating less vibration than V-type and most in-line engines for exceptional durability and reliable performance.

Packing a solid punch. And counterpunch.

THE DIFFERENCE:

The horizontally opposed design of the SUBARU BOXER engine fires with a powerful punch-counterpunch action.

THE ADVANTAGE:

It's naturally balanced for exceptional smoothness, inherently rigid for greater strength and has a lower profile for better handling.



2.5-LITRE SOHC SUBARU BOXER

HORSEPOWER: 170 HP @ 6000 RPM

TORQUE: 170 LB-FT @ 4400 RPM

FUEL ECONOMY (L/100 KM):

CITY 10.8 / HWY 7.4 (5MT)

CITY 10.4 / HWY 7.5 (4EAT)

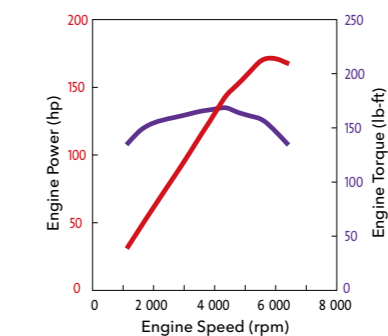

The naturally aspirated 2.5-litre 4-cylinder SUBARU BOXER features advanced electronic throttle control and the i-Active Valve Lift System to create superb low- and mid-range torque and impressive fuel efficiency. Sure, smooth and predictable power is generated throughout the rev range, making the Impreza a sporty and efficient way to go. A proven design incorporating lightweight and high-strength aluminum alloy, this engine is also extremely reliable and durable.

Enjoyment in every gear.

THE DIFFERENCE:

The Impreza offers a choice of transmissions, each one mated to its own variation of Subaru symmetrical full-time AWD to optimize traction and power delivery.

THE ADVANTAGE:

Choice means you are always in control, so you can select the system that best suits your driving needs.

4-SPEED AUTOMATIC TRANSMISSION + MULTI-PLATE TRANSFER CLUTCH AWD

For instant and seamless response to varying driving conditions, the optional 4-speed Electronic Direct Control Automatic Transmission with Manual Mode utilizes a multi-plate transfer clutch AWD system. This transmission allows the driver to shift gears manually or choose from two fully automatic modes (Normal and Sport). The multi-plate transfer clutch AWD system maintains a 60/40 torque split (front/rear) for more predictable handling and automatically adjusts up to a 50/50 split under hard acceleration or when conditions warrant. Using sensors to monitor individual wheel speeds, steering angle, lateral and rotational forces, the AWD system is able to team with the standard Vehicle Dynamics Control (VDC) system to control and distribute power to all four wheels to generate superior traction – on virtually any road surface at any time.

5-SPEED MANUAL TRANSMISSION + VISCOUS-COUPLING LIMITED-SLIP CENTRE DIFFERENTIAL AWD

Standard on all Impreza models is a slick-shifting 5-speed manual transmission paired with an AWD system using a viscous-coupling limited-slip centre differential. This system maintains a 50/50 torque split and incorporates VDC to ensure sporty performance under all conditions. This is the transmission of choice for those who crave maximum control and maximum driving pleasure.



Drivetrain for illustrative purposes only.

Exhilaration in every turn.

THE DIFFERENCE:

The Impreza's unique engineering allows for solid, responsive handling while providing a smooth, composed ride.

THE ADVANTAGE:

Confidence in all conditions, and satisfaction in every situation, comes from competence at all four wheels.

SUBARU DYNAMIC CHASSIS CONTROL CONCEPT

The inherent advantages of the Subaru Impreza's signature drivetrain layout – sporty handling, innate balance and superior control – have been taken one step further with the Subaru Dynamic Chassis Control Concept. Refinements such as a more robust body structure with a stronger chassis, a lower positioned engine and the addition of an advanced double-wishbone rear suspension place the Impreza one step ahead. Together these enhancements deliver more accurate, natural steering, a smoother ride and a safer, confidence-inspiring driving experience at every turn.

FRONT SUSPENSION

The Impreza's highly rigid strut-type front suspension is remarkably light and finely tuned to optimize steering feel and handling precision. A long stroke and wide track provide an ideal balance of stable handling, flat cornering and a composed ride.

REAR SUSPENSION

Expertly combining sporty response with smooth ride quality, the subframe-mounted double-wishbone rear suspension handles bumps and corners with equal precision and poise. This design also helps to create a generous cargo area.



Always the perfect fit.

For every aspect of your life, the Subaru Impreza has something to offer. Its smart design, convenience and versatility make it adaptable for whatever your day brings.





Well-proportioned outside. Well-planned inside.

On the surface, the exterior design of the Impreza displays modern style and an efficient, compact size that suits its fun-to-drive personality. But the interior is where driving enjoyment comes into sharp focus for everyone, thanks to two different body styles – both equipped with ample space and versatility for five passengers. The doors open wide, allowing for easy entry. Smart design and thoughtful features put everything important within close reach. And the sporty, premium feel to all the materials makes time on the road all the more enjoyable. The 2011 Subaru Impreza: designed for comfort, built for fun.



Control. Right where you want it. Right when you need it.

The Impreza's cockpit quickly reveals its dynamic nature in the convenience it provides. Driving controls have a consistent, natural feel in your hands. And contoured seats are always right by your sides, supporting you in the corners and encouraging your enthusiasm.



BLUETOOTH® HANDS-FREE CALLING

An available voice-activated Bluetooth hands-free system* pairs easily to your compatible mobile phone for hands-free calling. Calls can be accessed via voice commands and steering wheel controls.

**2.5i Convenience Package, 2.5i Sport Package and 2.5i Limited Package.*



SPORT STEERING WHEEL

The 3-spoke sport steering wheel is perfectly designed to ensure driver comfort and control at all times. The evidence: standard cruise control switches, available leather-wrapped trim and audio controls.



SPORT GAUGES

Sport gauges are illuminated in red for easy visibility while the needles make a full sweep on start-up. The message here: Being in control is rarely this exciting.

Completely comforted. Thoroughly entertained.

The Impreza is designed to make any journey fun, relaxing and entertaining for the driver and passengers alike. Premium sound comes with easy accessibility options to help you get the most enjoyment from your music, whether you're travelling with friends or driving solo.



AUDIO SYSTEM

Equipped with a single-disc CD player, four speakers and available tweeters, the AM/FM/MP3/WMA audio system turns the Impreza into a rolling concert hall with crisp, clear reproduction and impressive sound overall. Speed-sensitive volume control and the Radio Data System are standard on all versions, while steering-wheel audio controls are available on select models*.

**2.5i Convenience Package, 2.5i Sport Package and 2.5i Limited Package.*



AUXILIARY AUDIO INPUT AND MEDIAHUB

Plug your iPod® or other mobile music device into the Impreza's standard auxiliary audio input jack or available MediaHub* with USB port and your digital music plays through the vehicle's audio system. And when your iPod is connected to the USB port, you can conveniently access your playlist via steering wheel controls. The audio system is also MP3-compatible, letting you listen from the in-dash CD player or stream sound from your Bluetooth®-enabled player on select models.

**2.5i Convenience Package, 2.5i Sport Package and 2.5i Limited Package.*



SIRIUS® SATELLITE RADIO

Select Impreza models* come standard with SIRIUS Satellite Radio and a free 3-month trial subscription. With over 100 satellite radio channels on the dial, you're certain to find exactly what you're looking for – everything from music to news, sports and talk radio.

**2.5i Sport Package and 2.5i Limited Package.
Accessory and subscription required for 2.5i and 2.5i Convenience Package models.*



2.5i Convenience Package

Where imagination meets functionality.

Whether you're driving the 4-door or 5-door Impreza, thoughtful interior design and maximum efficiency are the rule. The compact rear suspension doesn't just handle corners with ease, it also handles cargo better. The luggage area is among the widest in its class and the 60/40-split rear seats fold flat to expand cargo capacity and accommodate longer items. Having smart options means you're prepared for any eventuality.



BIGGER IDEAS FOR LITTLE SPACES

Beyond roomy, the Impreza offers a place for life's little things. Pockets in each door include bottle holders while the centre console includes cup holders, a tray, and an armrest that opens to reveal added storage and a 12V power outlet.



SPACIOUS 4-DOOR

The Impreza 4-door offers the security of a spacious, separate trunk with the versatility of 60/40-split folding rear seats for extendable cargo space with a flat, carpeted floor. Even with the seats up, the trunk can hold three golf bags.



VERSATILE 5-DOOR

The Impreza 5-door can accommodate five passengers and five carry-on suitcases all at once. While rear seats fold flat to the cargo floor, a nearly square rear gate opening further eases loading and storage possibilities.



2.5i Convenience Package shown with accessory cargo cover

Thoughtfully equipped, inside and out.



Power Glass Sunroof
(2.5i Sport and 2.5i Limited Packages)

The power glass sunroof with manual sunshade delivers a panoramic view and fresh breezes for front and rear passengers.



Front Sport Seats
(2.5i Limited Package)

Body-hugging rally sport-style front seats are highly supportive during active driving and provide endless comfort for those long adventures behind the wheel.



Cruise Control

One-touch control allows the driver to set and maintain a steady cruising speed, convenient for long-distance driving on open highways.



Automatic Climate Control
(2.5i Limited Package)

Available automatic climate control maintains your comfort settings with automatic adjustment of airflow and temperature. A microscopic filter helps keep dust out of the cabin.



16-inch Aluminum Alloy Wheels
(2.5i Convenience and 2.5i Sport Packages)

Standard on 2.5i Convenience and 2.5i Sport Packages, these generously sized 12-spoke aluminum alloy wheels perfectly suit the Impreza's genuine sportiness and style.



17-inch Aluminum Alloy Wheels
(2.5i Limited Package)

The Impreza 2.5i Limited Package features the high-tech, high-performance appeal of 10-spoke 17-inch aluminum alloy wheels.



Low-profile Spoiler
(2.5i Sport and 2.5i Limited Packages)

Racy styling and aerodynamic efficiency come courtesy of the trunk-mounted rear spoiler on 4-door models.



Roofline Spoiler

Inspired by the world of rally racing, the roof-mounted spoiler on 5-door models improves both aerodynamics and appearance.



Front Cup Holders

Driver and passenger enjoy convenient cup holders to keep beverages secure yet easy to access.



Heated Front Seats
(2.5i Sport and 2.5i Limited Packages)

For instant comfort on cold mornings, available front seat heaters are individually adjustable via high/low level settings.



Seatback Pocket

Behind the front passenger seat is a pocket that can store maps, magazines and the like.



Retractable Cargo Cover
(2.5i Sport and 2.5i Limited Packages)

The available cargo cover on Impreza 5-door models is retractable or removable and features a rigid, lightweight aluminum frame.



Windshield Wiper De-icer
(2.5i Sport and 2.5i Limited Packages)

Electric heating elements warm the area of the windshield where the wipers rest to keep them free from ice and frost.



Fog Lights
(2.5i Sport and 2.5i Limited Packages)

Multi-reflector halogen fog lights emit a wide, flat beam that reflects less glare in fog for added safety.



Power-adjustable Door Mirrors

Generous door mirrors are aerodynamically sculpted for reduced wind noise, heated to defog or melt away frost, power-adjustable to create superior visibility and foldable to better fit narrow parking spaces.



Integrated Crossbar Brackets

Standard integrated crossbar brackets (fitted with accessory crossbars) set the stage for bicycle, ski and kayak carriers – and boost versatility.



Peace of mind is all around you.
Always.

Whatever path you choose, take comfort in knowing your Subaru Impreza is prepared for whatever's ahead, always looking out for your safety so you can focus on enjoying the drive.



Fully committed to fully protecting.

THE DIFFERENCE:

The Subaru Impreza's AWD, agility and active safety systems help keep you out of harm's way, while its smart construction and advanced technologies are ready for impact, just in case.

THE ADVANTAGE:

Subaru knows the best way to survive a collision is to avoid one in the first place. But if a crash is inevitable, take comfort in knowing you're in capable hands.

ACTIVE SAFETY, TO AVOID A COLLISION

Many of the same features that make an Impreza fun to drive also help to keep its occupants safe. The stable, responsive handling of Subaru symmetrical full-time AWD. The SUBARU BOXER engine's low centre of gravity. Vehicle Dynamics Control[†], surefooted suspension, anti-lock brakes and quick steering – all provide the driver with the excellent evasive capabilities needed to avoid an accident altogether.

PASSIVE SAFETY, TO LESSEN THE CHANCE OF INJURY

Sometimes an accident is unavoidable. For this reason, the Impreza is designed with occupant protection as a top priority. Its body structure is strategically strengthened in critical areas to help minimize the impact energies that reach the cabin. Front airbags, front-side and side curtain airbags, active front-seat head restraints[†] and 3-point seatbelts further contribute to the cause of passive safety. This is a core value of the Subaru philosophy: Peace of mind is crucial to fully experience true driving enjoyment.

[†]Excluding 2.5i Limited Package.

SEATS, SEATBELTS AND AIRBAGS

Height-adjustable front seatbelts with pretensioners hold passengers firmly in place while load limiters ease peak forces to the chest. Active front-seat head restraints[†] are positioned to better support a passenger's head in a rear collision. Also standard: Front, front-side and side curtain airbags as well as an ISO-FIX/LATCH anchor system for easier installation of compatible child safety seats.

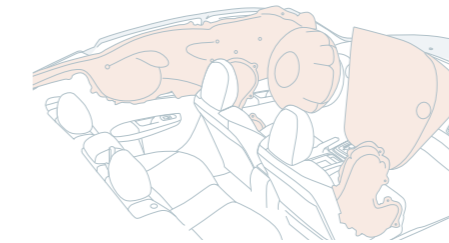

RING-SHAPED REINFORCEMENT FRAME

The advanced ring-shaped reinforcement frame strengthens the passenger cabin from the roof to the doors, pillars and floor. This design helps to divert impact energy away from the occupants in a collision. The Impreza also features crumple zones (front and rear) engineered to dissipate impact energy gradually while the front is also designed to allow the SUBARU BOXER engine to slide under the passenger compartment in a severe front-end collision.

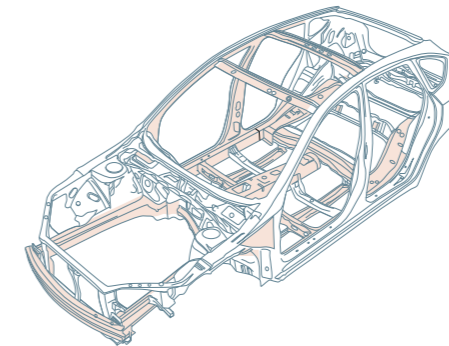

BRAKING SYSTEM

While the standard 4-channel Anti-lock Braking System (ABS) helps the driver maintain steering control under hard braking, Electronic Brake-force Distribution automatically adjusts the front/rear braking pressure as the vehicle load changes. Brake Assist provides greater force in sudden braking situations. And on manual transmission models, Subaru's Hill Holder feature helps prevent rollback during uphill starts by maintaining brake pressure for an extra second after you lift your foot off the brake pedal.

VEHICLE DYNAMICS CONTROL SYSTEM

The Vehicle Dynamics Control[†] system monitors and analyzes whether the vehicle is following the driver's intended course via an array of sensors. If the vehicle approaches the limits of stability while cornering or avoiding an obstacle, the AWD torque distribution*, engine output and brakes at each wheel will adjust to help keep the vehicle on course.

*Automatic transmission models only.

[†]The Subaru Vehicle Dynamics Control system may also be known as Electronic Stability Control.

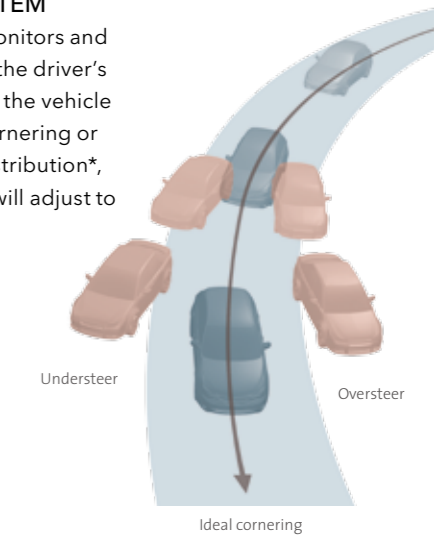

PEDESTRIAN PROTECTION

The Impreza was also designed with the objective of providing a high level of pedestrian protection. Shock-absorbing space between the hood and engine helps to reduce pedestrian injury in an accident, as do an energy-absorbing front bumper and a specially designed area around the windshield wipers.



¹**INSURANCE INSTITUTE FOR HIGHWAY SAFETY**



²**NATIONAL HIGHWAY TRAFFIC SAFETY ADMINISTRATION'S (NHTSA'S) NEW CAR ASSESSMENT PROGRAM**

2010 model year ratings. ¹Ratings of "Good" are the highest rating awarded for 40-mph frontal offset, 31-mph side-impact and 20-mph rear-impact crash tests conducted by the Insurance Institute for Highway Safety (IIHS) (www.iihs.org). A "Good" rating obtained in all three crash tests plus a "Good" rating in new roof strength testing and the availability of Electronic Stability Control (ESC) (Vehicle Dynamics Control) achieves a 2010 Top Safety Pick. ²U.S. Government star crash-test ratings are part of the National Highway Traffic Safety Administration's (NHTSA's) New Car Assessment Program (www.safercar.gov). A five-star crash-test rating is the highest government rating for a) Driver and right front seating positions in frontal crash tests and b) Front seating positions in side-impact crash tests.

LINEUP

IMPREZA 2.5i

Selected standard features:

Horizontally opposed, 4-cylinder, 2.5L SUBARU BOXER engine with i-Active Valve Lift System

170 horsepower and 170 lb-ft of torque

5-speed Manual Transmission (5MT) with Hill Holder system or optional 4-speed Electronic Direct Control Automatic Transmission with Manual Mode (4EAT)

Subaru symmetrical full-time All-Wheel Drive

Vehicle Dynamics Control system and Traction Control System

Anti-lock Braking System, Electronic Brake-force Distribution (EBD) and Brake Assist

Driver and front passenger front and side-impact airbags; side curtain airbags

16-inch steel wheels with wheel covers

Power-adjustable, foldable, heated, body-colour door mirrors; body-colour door handles

Rear roofline spoiler with integrated brake light (5-door)

AM/FM/CD/MP3/WMA audio system with 4 speakers, auxiliary audio input, Radio Data System, vehicle-speed-sensitive volume and SIRIUS® Satellite Radio compatible†

Air conditioning with air filtration

Tilt-adjustable steering wheel with integrated cruise controls

Power windows and door locks

60/40-split, flat-folding rear seats

Ebony cloth upholstery



Fuel economy: 5MT (L/100 km): City 10.8 / Hwy 7.4 4EAT (L/100 km): City 10.4 / Hwy 7.5



Exterior colours available: Camellia Red Pearl (shown), Dark Grey Metallic, Marine Blue Pearl*, Obsidian Black Pearl, Satin White Pearl (shown), Spark Silver Metallic, World Rally Blue Pearl.

Interior colour: Ebony (shown).

CONVENIENCE PACKAGE

Upgrade features:

16-inch aluminum alloy wheels

Advanced AM/FM/CD/MP3/WMA audio system with 4 speakers, 2 tweeters and steering wheel-mounted audio controls

MediaHub for iPod®/USB audio integration with Bluetooth® streaming audio

Voice-activated Bluetooth hands-free system with steering wheel-mounted controls

Leather-wrapped gear selector and steering wheel

SPORT PACKAGE

Upgrade features:

16-inch aluminum alloy wheels

Aerodynamic body-colour ground effects

Power tilting and sliding glass sunroof

Multi-reflector halogen fog lights

Low-profile rear spoiler with integrated brake light (4-door)

Stainless steel exhaust tip(s)

Rear underbody aerodynamic diffuser (5-door)

Windshield wiper de-icer

Advanced AM/FM/CD/MP3/WMA audio system with 4 speakers, 2 tweeters and steering wheel-mounted audio controls

SIRIUS Satellite Radio installed (free 3-month trial subscription included)

MediaHub for iPod/USB audio integration with Bluetooth streaming audio

Voice-activated Bluetooth hands-free system with steering wheel-mounted controls

Leather-wrapped gear selector and steering wheel

Heated front seats

Retractable cargo cover (5-door)

LIMITED PACKAGE

Upgrade features:

17-inch aluminum alloy wheels

Aerodynamic body-colour ground effects

Power tilting and sliding glass sunroof

Multi-reflector halogen fog lights

Low-profile rear spoiler with integrated brake light (4-door)

Stainless steel exhaust tip(s)

Rear underbody aerodynamic diffuser (5-door)

Windshield wiper de-icer

Advanced AM/FM/CD/MP3/WMA audio system with 4 speakers, 2 tweeters and steering wheel-mounted audio controls

SIRIUS Satellite Radio installed (free 3-month trial subscription included)

MediaHub for iPod/USB audio integration with Bluetooth streaming audio

Voice-activated Bluetooth hands-free system with steering wheel-mounted controls

Leather-wrapped gear selector and steering wheel

Automatic climate control

Heated, rally sport-style front seats

Retractable cargo cover (5-door)

Leather seating surfaces

See 2011 Subaru Impreza specification insert for full details and colour samples. †Dealer accessory and subscription required. *Not available on 2.5i Sport Package or 2.5i Limited Package.

ACCESSORIES

While every Impreza comes generously equipped, Genuine Subaru accessories are the perfect way to tailor your Subaru to your life and your style. Whether you want to add convenience, enhance functionality, or personalize your Impreza's appearance, they are designed to provide the same fit and quality as your Subaru vehicle. The rational side of your brain decided to pick the Impreza, why not give your creative side a chance to shine too?

- Armrest extension
- blueconnect® Bluetooth® hands-free system
- Body side moulding kit
- Bumper underguard (front and rear)
- Cargo area cover (retractable) (5-door)
- Cargo area organizer
- Cargo area nets (floor, rear, side, seatback) (5-door)
- Cargo area tray
- Cup holder (rear seat)
- Fog lights
- Footwell illumination kit (blue or red)
- Front end cover (full and half)
- Front lip spoiler
- Ground effects – front under spoiler, side under spoiler (rear under spoiler also on 5-door)
- Hood deflector
- Kayak stacker
- MediaHub for iPod®/USB audio integration (also available with Bluetooth streaming audio)
- Rear bumper step pad (5-door)
- Rearview mirror – auto-dim with compass and HomeLink®
- Remote engine starter kit (4EAT)
- Roof cargo box (several styles and sizes)
- Rubber floor mats
- Satellite radio kit (SIRIUS®)
- Security system upgrade – shock sensor
- Side window deflectors
- Short-throw shifter (SMT)
- Splash guards
- Subwoofer/amplifier

For more accessory options, visit subaru.ca or your local Subaru dealer.



Impreza 2.5i 5-door (left) shown with 16-inch aluminum alloy wheels, fog lights, mesh front grille, front under spoiler, side under spoiler and side window deflectors. Impreza 2.5i 4-door (right) shown with 16-inch aluminum alloy wheels, fog lights, chrome/mesh front grille, front under spoiler, side under spoiler and low-profile rear spoiler.



Mesh front grille



Bike carrier (roof-mounted) with crossbar set (each sold separately)



Ski/snowboard carrier with crossbar set (each sold separately)



Low-profile rear spoiler



Sunroof deflector



STI-branded pedal pad set



Shift knobs – Duracon, MOMO® (each sold separately)



Cargo area tray, retractable cover*, rear seatback net* and rear bumper step pad* (each sold separately, *5-door models only)

Subaru Warranties

Every Subaru vehicle is designed and built to offer our customers the highest possible level of quality and reliability. We are proud of our vehicles and proud to stand behind them with a comprehensive warranty. For 2011 model year vehicles, the warranty on all Subaru vehicles consists of the following:

New Vehicle Limited Warranty (36 month/60,000 km) – Covers basic and major components for 36 months or 60,000 km.

Major Component Limited Warranty (60 month/100,000 km) – Extends coverage of major components (more than just powertrain) up to 60 months or 100,000 km.

Surface Corrosion Limited Warranty (36 month/60,000 km) – Covers surface corrosion to visible painted body panels for 36 months or 60,000 km.

Anti-Perforation Limited Warranty (60 month/unlimited km) – Covers perforation due to corrosion to body sheet metal panels for 60 months, regardless of kilometres.

Emission Control System Limited Warranty – Covers the majority of emissions components for 36 months or 60,000 km and the major parts of the emission control system for 96 months or 130,000 km.

Parts and Accessories Limited Warranty – Covers Subaru parts and accessories installed by the dealer prior to retail delivery of the vehicle for 36 months or 60,000 km, and Subaru parts and accessories installed by the dealer after the retail delivery of the vehicle for 12 months or 20,000 km from the date of the installation.

The above information is an overview of warranty coverage and is not a warranty statement. If you wish to see more details regarding Subaru warranties, please refer to your Subaru warranty booklet, contact your local dealer or visit our Web site at subaru.ca.

Subaru C.A.R.E. (Customer Assistance for Roadside Emergencies)

The Subaru C.A.R.E. program (which is backed by the Canadian Automobile Association [CAA]) is offered free of charge for the first three years from date of purchase on every new Subaru vehicle or as part of a Subaru Protection Plan. As a Subaru C.A.R.E. member, you can count on fast, courteous emergency roadside assistance 24 hours a day, 365 days a year. You will receive a membership card and have access to a dedicated toll-free telephone number (in English or French), allowing you to take advantage of over 20,000 roadside assistance contractors and 1,000 CAA and American Automobile Association (AAA) offices throughout Canada and the United States. Ask your dealer for details or visit subaru.ca.

Subaru Canada, Inc. is proud to be the first vehicle manufacturer to have a direct relationship with CAA, giving our customers the benefit of CAA's unparalleled level of experience and service.

Subaru Protection Plan

As a Subaru owner, you have expectations for a pleasurable, trouble-free ownership experience – now and into the future. Once your 36-month/60,000-km New Vehicle Limited Warranty period ends,* our Subaru Protection Plan (SPP) – the only vehicle service contract endorsed by Subaru Canada for Subaru vehicles – can prolong your hassle-free ownership experience with three levels of extended service contract coverage tailored to your needs: Powertrain Protection; Major Protection; or Complete Protection (best level of coverage to complement the 60-month/100,000-km Major Component Limited Warranty). SPP offers comprehensive mechanical and electrical coverage and a number of additional features and benefits, such as Roadside Assistance and Alternate Transportation, for up to 7 years or 160,000 kilometres from your vehicle's in-service date. Whether your vehicle is purchased or leased, SPP protects you and your investment. Be sure to ask your dealer for details or visit subaru.ca.

*If you already own a Subaru vehicle and it is still within the 36-month/60,000-km New Vehicle Limited Warranty period, you are still eligible for SPP!



2011 IMPREZA SPECIFICATIONS

ENGINE

**2.5i, 2.5i Convenience Package,
2.5i Sport Package, 2.5i Limited Package**

Type 2.5L Single Overhead Cam (SOHC), 16-valve, horizontally opposed, 4-cylinder SUBARU BOXER engine, Electronic Throttle Control and i-Active Valve Lift System

Power 170 hp @ 6000 rpm

Torque 170 lb-ft @ 4400 rpm

All Impreza engines meet Low Emission Vehicle (LEV2) standards.

TRANSMISSION AND DRIVETRAIN

Standard 5-speed Manual Transmission (5MT)
Hill Holder system
Viscous-coupling limited-slip centre differential

Optional 4-speed Electronic Direct Control Automatic Transmission with Manual Mode (4EAT)
Electronically controlled multi-plate transfer clutch

All models are equipped with a Subaru symmetrical full-time All-Wheel Drive system.

FUEL ECONOMY

5MT City 10.8 / Hwy 7.4 (L/100 km)

4EAT City 10.4 / Hwy 7.5 (L/100 km)

Recommended minimum octane: 87

MEASUREMENTS (Measurements based on entry models)

	2.5i (4-door)	2.5i (5-door)
Curb weight: Manual transmission (kg)	1390	1390
Curb weight: Automatic transmission (kg)	1420	1420
Length (mm)	4580	4415
Width (mm) with mirrors	1976	1976
Height (mm)	1475	1475
Wheelbase (mm)	2620	2620
Minimum ground clearance (at curb weight) (mm)	155	155
Steering: Minimum turning circle (curb-to-curb) (m)	10.6	10.6
Headroom: Front/rear (mm)	1023 (998*) / 954	1023 (998*) / 954
Legroom: Front/rear (mm)	1105/852	1105/852
EPA passenger volume (L)	2678	2678
Cargo area: EPA trunk volume (L)	320	-
Cargo area: Cargo volume (seats up) (L)	-	538
Cargo area: Cargo volume (seats folded flat) (L)	-	1257
Cargo area: Floor length (seats folded flat) (mm)	1527	1527
Cargo area: Floor length (seats up) (mm)	-	805
Cargo area: Height (mm)	-	675
Cargo area: Width between wheel wells (mm)	-	1067

*Sunroof equipped models.

2011 IMPREZA

CHASSIS

	2.5i 4-door	2.5i 5-door
•	•	Brakes: Anti-lock Braking System with Electronic Brake-force Distribution (EBD)
•	•	Brakes: Brake Assist
•	•	Brakes (front): Ventilated discs (277 x 24 mm), dual-piston calipers
•	•	Brakes (rear): Solid discs (286 x 10 mm), single-piston calipers
•	•	Structure: Advanced ring-shaped reinforcement frame
•	•	Structure: Dual, side-impact door beams (front and rear)
•	•	Suspension: 4-wheel fully independent
•	•	Suspension (front): MacPherson strut
•	•	Suspension (rear): Double-wishbone

SAFETY AND SECURITY

	2.5i 4-door	2.5i 5-door
•	•	Airbags (SRS): Driver dual-stage deployment
•	•	Airbags (SRS): Front passenger dual-stage deployment with occupant detection system
•	•	Airbags (SRS): Front seat side-impact
•	•	Airbags (SRS): Side curtain
•	•	Child safety: Rear door locking system
•	•	Child safety: Rear seat ISO-FIX/LATCH anchor system
•	•	Head restraints (front): Height-adjustable, active
LP	LP	Head restraints (front): Integrated
•	•	Head restraints (rear): Height-adjustable
•	•	Seatbelts (front): 3-point height-adjustable with pretensioners and load limiters (Driver - ELR / Passenger - ALR)
•	•	Seatbelts (rear): 3-point, all seating positions (ALR)
•	•	Security: Anti-theft system and engine immobilizer system
•	•	Security: Keyless entry system with panic alarm
•	•	Traction Control System
•	•	Vehicle Dynamics Control system with lateral-g and yaw-rate sensor

EXTERIOR

	2.5i 4-door	2.5i 5-door
-	SP/LP	Body: Underbody rear aerodynamic diffuser
•	•	Door mirrors: Power-adjustable, foldable and heated (body colour)
•	•	Door handles: Body colour
•	-	Exhaust: Twin mufflers
-	•	Exhaust: Single outlet muffler
SP/LP	SP/LP	Exhaust: Stainless steel tip(s)
SP/LP	SP/LP	Fog lights: Multi-reflector halogen
•	•	Headlights: Auto-off with ignition switch
•	•	Headlights: Contoured multi-reflector halogen (high beam)
•	•	Headlights: Projector beam halogen (low beam)
SP/LP	SP/LP	Sunroof: Glass, power tilting and sliding with sunshade
•	•	Roof rack: Integrated crossbar brackets
SP/LP	SP/LP	Side moulding: Aerodynamic body-colour side ground effects
SP/LP	-	Spoiler: Low-profile, integrated brake light
-	•	Spoiler: Roofline, integrated brake light
•	•	Tires: 205/55 R16 89V Bridgestone® Potenza™ RE92A M+S All-Season
LP	LP	Tires: 205/50 R17 88V Bridgestone Potenza RE92A M+S All-Season
CP/SP	CP/SP	Wheels: 16" x 6.5" aluminum alloy, 12-spoke design
LP	LP	Wheels: 17" x 7" aluminum alloy, 10-spoke design
SP/LP	SP/LP	Windshield: Wiper de-icer
•	•	Wipers (windshield): Variable intermittent with washer
-	•	Wiper (rear window): Fixed intermittent with washer

2.5i 4-door
2.5i 5-door

AUDIO AND TECHNOLOGY

		• • Audio system: AM/FM/CD/MP3/WMA
CP/SP/LP	CP/SP/LP	Audio system: Advanced AM/FM/CD/MP3/WMA
		• • Auxiliary input: Audio source in armrest console
CP/SP/LP	CP/SP/LP	Audio controls: Illuminated, steering wheel integrated
CP/SP/LP	CP/SP/LP	Bluetooth® hands-free system: Voice-activated with steering wheel-mounted controls
CP/SP/LP	CP/SP/LP	MediaHub: iPod®/USB audio integration with Bluetooth streaming audio
		• • SIRIUS® Satellite Radio compatible (dealer accessory required)
SP/LP	SP/LP	SIRIUS Satellite Radio installed (free 3-month trial subscription included)
		• • Speakers: 4-speaker system
CP/SP/LP	CP/SP/LP	Speakers: 2 tweeters
		• • Radio Data System
		• • Vehicle-speed-sensitive volume

INSTRUMENTS

		• • Gauges: Analog with red illuminated needles
		• • Gauges: Full needle sweep on start-up
		• • Information display: Clock, ambient temperature, fuel economy (average and real time)
		• • Instrument panel: Coolant temperature indicator
		• • Instrument panel: Fuel gauge with low fuel warning light and fuel door location indicator
		• • Odometer: Digital, dual trip modes
		• • Tachometer: 8000 rpm maximum

2.5i 4-door
2.5i 5-door

SEATING AND TRIM

		• • Accents/trim: Titanium finish
		• • Floor mats: Carpet
		• • Interior: Ebony cloth
LP	LP	Interior: Leather seating surfaces
CP/SP/LP	CP/SP/LP	Gear selector: Leather-wrapped
		• • Parking brake: Soft-grip
		• • Seat (driver's): 6-way manually adjustable
		• • Seat (front): Passenger, 4-way manually adjustable
SP/LP	SP/LP	Seats (front): Heated with high/low level settings
LP	LP	Seats (front): Rally-sport style
		• • Seats (rear): 60/40-split, flat-folding
CP/SP/LP	CP/SP/LP	Steering wheel: Leather-wrapped

CARGO AREA

-	SP/LP	Cargo cover: Retractable
-	•	Cargo tie-down hooks (4)
-	•	Light: Cargo area, on/off switch
•	-	Light: Trunk
•	-	Remote trunk release, floor-mounted (driver's side)
•	•	Storage: Sub-floor tray
-	•	Utility hooks (2)

2.5i 4-door
2.5i 5-door

COMFORT AND CONVENIENCE

		• • Armrest (front): With console storage
		• • Climate control: Air conditioning with air filtration
LP	LP	Climate control: Automatic
		• • Cruise control: Steering wheel integrated
		• • Glove box: Lockable and illuminated
		• • Ignition key ring: Illuminated
		• • Light: Interior dome with off delay and map spotlights
		• • Power outlet: 12V in armrest console and in dash
		• • Remote starter: Pre-wired (accessory kit required) (4EAT only)
		• • Steering wheel: Tilt-adjustable
		• • Storage: Centre console with coin tray and integrated cup holders (2)
		• • Storage: Door compartments with integrated cup holders
		• • Storage: Passenger seatback pocket
		• • Storage: Illuminated tray, centre console
		• • Visor: Dual, with mirrors
		• • Windows (power): Driver's window auto down

- standard
- CP** Convenience Package
- SP** Sport Package
- LP** Limited Package

AVAILABLE PACKAGES

CONVENIENCE PACKAGE: Available on 2.5i

- 16-inch aluminum alloy wheels
- Advanced AM/FM/CD/MP3/WMA audio system with 4 speakers, 2 tweeters and steering wheel-mounted audio controls
- MediaHub for iPod/USB audio integration with Bluetooth streaming audio
- Voice-activated Bluetooth hands-free system with steering wheel-mounted controls
- Leather-wrapped gear selector and steering wheel

Additional packages on back.

AVAILABLE PACKAGES

SPORT PACKAGE: Available on 2.5i

- 16-inch aluminum alloy wheels
- Aerodynamic body-colour side ground effects
- Rear underbody diffuser (5-door)
- Stainless steel exhaust tip(s)
- Windshield wiper de-icer
- Low-profile spoiler with integrated brake light (4-door)
- Multi-reflector halogen fog lights
- Power tilting and sliding glass sunroof

- Advanced AM/FM/CD/MP3/WMA audio system with 4 speakers, 2 tweeters and steering wheel-mounted audio controls
- MediaHub for iPod/USB audio integration with Bluetooth streaming audio
- Voice-activated Bluetooth hands-free system with steering wheel-mounted controls
- SIRIUS Satellite Radio installed (free 3-month trial subscription included)
- Leather-wrapped gear selector and steering wheel
- Retractable cargo cover (5-door)
- Heated front seats

LIMITED PACKAGE: Available on 2.5i

- 17-inch aluminum alloy wheels
- Aerodynamic body-colour side ground effects
- Rear underbody diffuser (5-door)
- Stainless steel exhaust tip(s)
- Windshield wiper de-icer
- Low-profile rear spoiler with integrated brake light (4-door)
- Multi-reflector halogen fog lights
- Power tilting and sliding glass sunroof
- Automatic climate control

- Advanced AM/FM/CD/MP3/WMA audio system with 4 speakers, 2 tweeters and steering wheel-mounted audio controls
- MediaHub for iPod/USB audio integration with Bluetooth streaming audio
- Voice-activated Bluetooth hands-free system with steering wheel-mounted controls
- SIRIUS Satellite Radio installed (free 3-month trial subscription included)
- Leather-wrapped gear selector and steering wheel
- Retractable cargo cover (5-door)
- Heated, rally sport-design front seats
- Leather seating surfaces

AVAILABLE COLOURS



Camellia Red Pearl



Dark Grey Metallic



Marine Blue Pearl

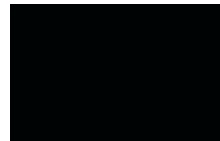

Obsidian Black Pearl

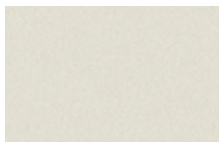

Satin White Pearl



Spark Silver Metallic



World Rally Blue Pearl



Ebony Cloth



Black Leather

	2.5i (4-door & 5-door)	2.5i Convenience Package (4-door & 5-door)	2.5i Sport Package (4-door & 5-door)	2.5i Limited Package (4-door & 5-door)
Camellia Red Pearl	EC	EC	EC	BL
Dark Grey Metallic	EC	EC	EC	BL
Marine Blue Pearl	EC	EC	-	-
Obsidian Black Pearl	EC	EC	EC	BL
Satin White Pearl	EC	EC	EC	BL
Spark Silver Metallic	EC	EC	EC	BL
World Rally Blue Pearl	EC	EC	EC	BL

EC Ebony Cloth BL Black Leather

The Supplemental Restraint System (SRS airbags) affords the driver and passenger additional protection in some collisions. This system provides supplemental protection only, and seatbelts must be worn in order to avoid injuries to out-of-position occupants upon airbag deployment. The combination of SRS and seatbelts provides the best protection in a serious accident. All illustrations, specifications, features and photographs contained in this brochure are based on product information available at the time of its printing, and may not be completely accurate following its publication. Colours shown may vary due to reproduction variations in the printing process, and some vehicle parts cannot be shown in certain photographs. Subaru Canada, Inc. reserves the right to discontinue or make changes at any time, without notice or incurring obligations, to colours, materials, equipment, accessories, features, specifications and models, or to change their prices. Please visit our Web site for the latest information and specifications. For complete details on product updates, warranties or the Subaru C.A.R.E. program, please contact your Subaru dealer. Impreza, Subaru and SUBARU BOXER are registered trademarks. blueconnect is a registered trademark of Johnson Controls, Inc. Bluetooth is a registered trademark of Bluetooth SIG, Inc. Bridgestone and any Bridgestone products or service names are trademarks or registered trademarks of Bridgestone Corporation. iPod is a registered trademark of Apple, Inc. SIRIUS and related marks are trademarks of SIRIUS Satellite Radio Inc. Printed in Canada. © 2010 Subaru Canada, Inc. 2011 model year.



Environmental Management System (EMS) ISO 14001:2004 certified by SGS.
Brochure is printed on 100% chlorine-free bleached pulp (TCF), contains up to 30% pre-consumer recycled fibre and uses UV cured inks that are VOC (Volatile Organic Compound) free to be fully recyclable with no harmful residue.

www.subaru-earth.com

SBI11ESPEC



The Supplemental Restraint System (SRS airbags) affords the driver and passenger additional protection in some collisions. This system provides supplemental protection only, and seatbelts must be worn in order to avoid injuries to out-of-position occupants upon airbag deployment. The combination of SRS and seatbelts provides the best protection in a serious accident. All illustrations, specifications, features and photographs contained in this brochure are based on product information available at the time of its printing, and may not be completely accurate following its publication. Colours shown may vary due to reproduction variations in the printing process, and some vehicle parts cannot be shown in certain photographs. Subaru Canada, Inc. reserves the right to discontinue or make changes at any time, without notice or incurring obligations, to colours, materials, equipment, accessories, features, specifications and models, or to change their prices. Some models shown may be from international markets and are not available in Canada, or they may be shown with equipment or accessories that are optional (at extra cost) or only available in certain combinations, or they may be subject to product delays or not be available in Canada. Please visit our Web site for the latest information and specifications. For complete details on product updates, warranties or the Subaru C.A.R.E. program, please contact your Subaru dealer. Impreza, Subaru, SUBARU BOXER, Subaru C.A.R.E. and Subaru C.A.R.E. Customer Assistance for Roadside Emergencies are registered trademarks. blueconnect is a registered trademark of Johnson Controls, Inc. Bluetooth is a registered trademark of Bluetooth SIG, Inc. HomeLink is a registered trademark of Johnson Controls, Inc. iPod is a registered trademark of Apple, Inc. SIRIUS and related marks are trademarks of SIRIUS Satellite Radio Inc. Printed in Canada. © 2010 Subaru Canada, Inc. 2011 model year.



Environmental Management System (EMS) ISO 14001:2004 certified by SGS
www.subaru-earth.com

This brochure is printed on 100% chlorine-free bleached pulp (TCF), contains up to 30% recycled fibre and 70% pre-consumer waste and uses vegetable-based inks to be fully recyclable with no harmful residue. Please recycle.

