

FORESTER

2005



www.subaru.ca



The Supplemental Restraint System (SRS airbags) affords the driver and passenger additional protection in some collisions. This system provides supplemental protection only, and seatbelts must be worn in order to avoid injuries to out-of-position occupants upon airbag deployment. The combination of SRS and seatbelts provides the best protection in a serious accident. All illustrations, specifications, features and photographs contained in this brochure are based on product information available at the time of its printing, and may not be completely accurate following its publication. Colours shown may vary due to reproduction variations in the printing process, and some vehicle parts cannot be shown in certain photographs. Subaru Canada Inc. reserves the right to discontinue or make changes at any time, without notice or incurring obligations, to colours, materials, equipment, accessories, features, specifications and models, or to change their prices. Some models shown may be from international markets and are not available in Canada, or they may be shown with equipment or accessories which are optional (at extra cost) or only available in certain combinations, or they may be subject to product delays or not be available in Canada. Please visit our web site for the latest information and specifications. For complete details on product updates, warranties or the Subaru Care program, please contact your Subaru Dealer. Subaru, Forester, SUBARU BOXER, Subaru CARE and Subaru CARE Customer Assistance for Roadside Emergencies are registered trademarks. Printed in Canada. 2004 Subaru Canada, Inc. 2005 Forester model year.



SBF05E

Think. Feel. Drive.

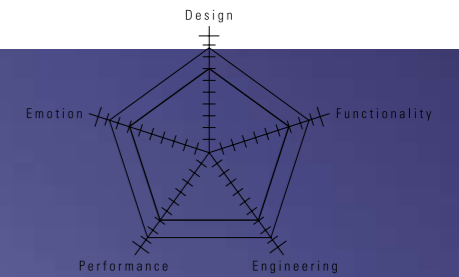

The Perfect Balance

Subaru Symmetrical AWD

Whether in the design of a skyscraper or the formation of a snowflake, symmetry creates balance. The Subaru symmetrical full-time All-Wheel Drive system was designed and engineered to achieve the pinnacle of automotive balance, providing unequalled safety and performance through a simple linear drivetrain configuration. The horizontally-opposed engine, All-Wheel Drive transmission and sophisticated suspension work in complete harmony to provide superior handling and control, which is why you'll feel at ease in the 2005 Forester – wherever your adventures take you.



SYMMETRICAL AWD



Advanced technology for an increasingly challenging world.

From modern, multi-lane highways to dusty, rock-strewn cottage trails you won't find on any map, the environment in which we drive is becoming increasingly challenging. That is why the 2005 Forester – and every vehicle Subaru builds – is designed and engineered with three simple words in mind: Think. Feel. Drive.

Every Subaru is the product of intelligent design, forward thinking and over 30 years of All-Wheel Drive expertise. Every Subaru is created with the feeling and passion our engineers have for the act of driving and for translating cutting-edge ideas into real-world technology.

Every Subaru is built to be driven and appreciated from both a practical standpoint and an emotional one.

By combining these three simple, yet integral concepts with the lessons we have learned in the heat of World Rally Championship competition, we have created an exceptionally versatile vehicle built from the ground up to handle the challenges of both your driving and lifestyle needs: the 2005 Forester.

SYMMETRICAL AWD



*- Petter Solberg & Phil Mills -
2003 FIA World Rally Championship for Drivers & Co-Drivers*

Forester.

For every life you lead.

The 2005 Forester is all about balance. Designed to both stimulate your senses and put your mind at ease, the Forester balances practicality and passion, ruggedness and refinement. With the commanding driving position and versatility no sedan can offer, the off-road capabilities and ground clearance no ordinary wagon can provide and the sedan-like fuel economy and driving experience no other compact SUV can match, the Forester lets you have it all. In the end, doesn't a dynamic lifestyle call for a dynamic vehicle?



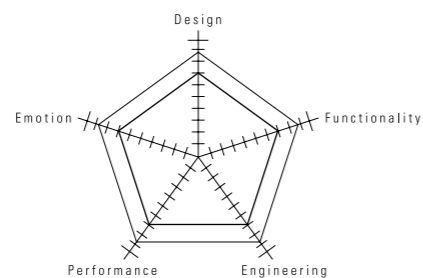

2.5XT

2.5XT

One vehicle, two worlds.

Designed as a "crossover" vehicle that can make a seamless transition from work to play, the 2005 Forester is well-equipped to handle both the stresses of the daily grind and the challenges of leisure time activities.

With advanced engineering, world-class safety and an available turbocharged engine, the Forester can bring calm and even fun to your everyday travels – while always being ready for whatever the weekend may bring.

Comforting thoughts.



You'll experience feelings of comfort and of everything being proportioned just right the first time you slip behind the wheel of the 2005 Forester. With a spirited personality, purposeful styling and sophisticated technology, you'll feel at one with the Forester and take pride in what it says

about you. Look a little deeper and you'll find reassurance in the build quality, world-class safety and performance attributes that are synonymous with the Subaru name. Each and every detail contributes to your satisfaction and enjoyment. Your seat is waiting for you.

The balance of
brains and brawn.

When it's time to head out of the city and enjoy nature, you'll want a vehicle with impressive versatility and off-road prowess – but not at the expense of responsiveness and a smooth ride. Enter the 2005 Forester. Combining a spacious cargo area, handy roof rails, excellent towing capacity, clever interior storage space and generous ground clearance with the performance benefits of Subaru symmetrical full-time All-Wheel Drive and a SUBARU BOXER engine, the Forester boasts a rugged and reliable balance of brains and brawn.



The best of both worlds.

From mountain biking adventures to a night out on the town, the 2005 Forester takes it all in stride. Created to satisfy the demand for a safe, versatile, yet performance-oriented "crossover" vehicle, the Forester can answer the

call of the wild and compliment your busy lifestyle. With style to turn heads in any urban centre and ability to travel off the beaten path, the all-purpose Forester is equally at home in the city or anywhere else your life may lead.



2.5XS



2.5XT

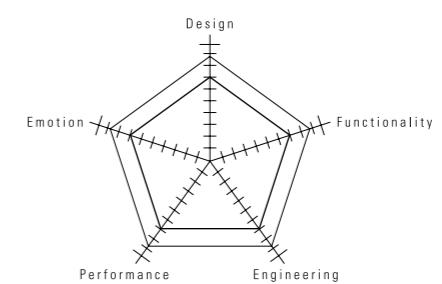



Escape the ordinary.

One look says it all: the Forester is built to handle any curve. Its sculpted wheel arches, aluminum alloy wheels, refined aerodynamics and athletic stance all add up to a commanding presence on the open road. Better yet, the Forester's authoritative styling is backed by its dynamic performance capabilities. With a sophisticated suspension and drivetrain delivering responsive handling and precise control plus the availability of a rally-bred, turbocharged engine, the Forester is a practical driving enthusiast's dream come true.

Forester.

You can have it all.

Stimulating and comforting, powerful and practical, the 2005 Forester offers best-in-class safety and unparalleled performance in an ideally sized package. With the safety, versatility and all-weather capabilities you need and the commanding driving position, refined driving dynamics and comfort you want, the Forester just may be the ideal balance of practicality and performance. Visit your local Subaru Dealer today to test drive a 2005 Forester – whether it be the value-packed 2.5X, the sophisticated and stylish 2.5XS and 2.5XS Premium or the exhilarating, turbocharged 2.5XT – and see how it can handle both life's adventures and the challenges of everyday driving in Canada.



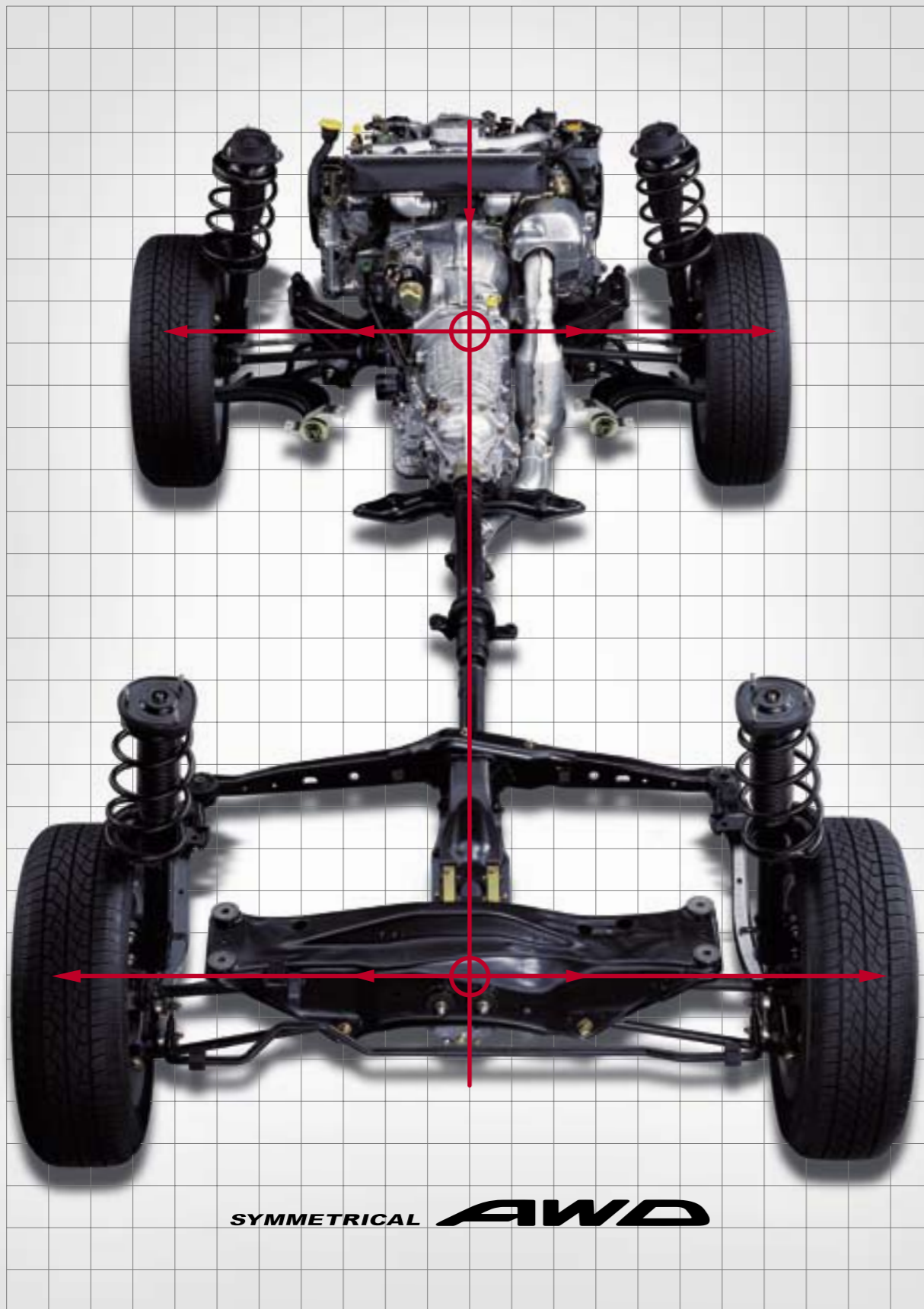

SYMMETRICAL AWD

The benefits of the Subaru symmetrical full-time All-Wheel Drive system are recognized the world over.

The superiority of Subaru AWD.

The symmetrical full-time All-Wheel Drive system, standard in every Subaru built for the Canadian market, is much more than the sum of its parts. It is the result of over 30 years of research and development. It is the product of rigorous testing in the heat of World Rally Championship (WRC) competition. It is the culmination of one company's unique quest to provide unparalleled safety and performance in all of its vehicles, regardless of road or weather conditions. Quite simply, it is our passion.

In contrast to conventional designs, Subaru strategically positions the engine, transmission and transfer case along the centreline of the vehicle to create an exceptionally balanced drivetrain. This simple layout provides superior handling and control while increasing driveline efficiency. In the end, the 2005 Forester's unique symmetrical full-time All-Wheel Drive system, including a limited-slip rear differential on all 2.5XS and 2.5XT models, provides exceptional levels of both performance and safety, translating into added driver confidence and enjoyment in virtually any road or weather condition.

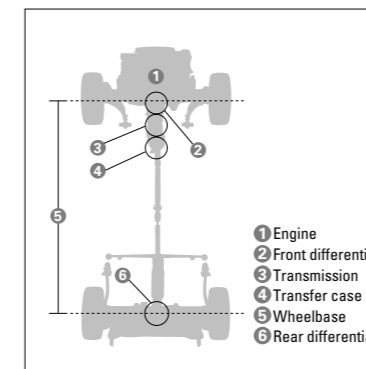

SUBARU BOXER



The higher the centre of gravity of a vehicle, the greater the compromise to the vehicle's handling and stability. That is why the 2005 Forester uses a horizontally-opposed "boxer" engine, with pistons that move horizontally, rather than vertically – like a boxer throwing an endless combination of perfect rights and lefts. Unlike the bulky size of most V-shaped or in-line configuration engines, the compact design of the SUBARU BOXER allows it to be mounted closer to the road and in harmony with the symmetrical layout of the drivetrain, lowering the Forester's centre of gravity and improving its balance. Also, all SUBARU BOXER engines are all-aluminum units whose low mass further contributes to solid handling and directional stability. With the natural smoothness, efficiency and responsiveness of its powerplant and the performance of symmetrical full-time AWD, the Forester equals pure driving pleasure.

DRIVE SUBARU



Push the envelope.

At Subaru, we believe advanced technology and innovative design can provide a balance between world-class safety and performance, inspiring driver confidence and a passion for the open road. Nowhere are these beliefs more evident than in the 2005 Forester. By combining the low centre of gravity of a SUBARU BOXER engine with the control and traction of symmetrical full-time All-Wheel Drive and the all-road benefits of long-travel suspension, the Forester offers superior vehicle dynamics as well as exceptional stability and grip. Whether tackling a winding mountain road on a clear autumn day or performing an emergency lane change in the dead of winter, the Forester has been designed and engineered from the ground up to create seamless communication between vehicle and driver, providing both exhilaration and peace



of mind.

Advantages of Subaru symmetrical full-time AWD and the SUBARU BOXER engine.

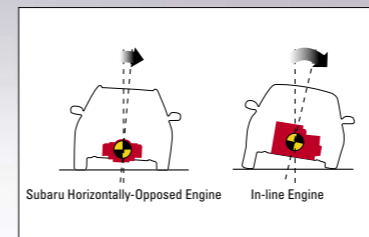

Better balance

During cornering, centrifugal force causes a vehicle to lean; how much it leans depends in part on the position of the vehicle's centre of gravity. Thanks to the placement of the compact, all-aluminum, horizontally-opposed SUBARU BOXER engine, the 2005 Forester boasts an exceptionally low centre of gravity, which helps improve handling and stability while reducing body roll and deviation from your chosen direction.

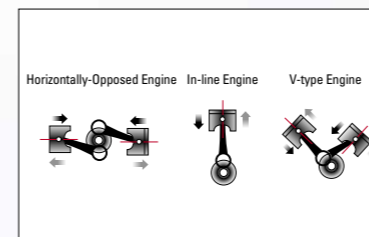

Less vibration

With its 180-degree configuration, Subaru's horizontally-opposed engine dramatically cuts down vibration by eliminating the inertia of opposing pistons that exists in some V-shaped or in-line configuration engines. The result with the SUBARU BOXER engine is smooth, seamless power right through the rev range and unprecedented driving comfort.

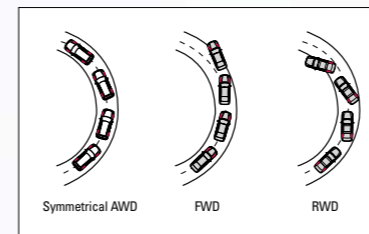

More grip and traction

One reason that Subaru has devoted so much time and energy to perfecting full-time All-Wheel Drive is the system's inherent advantages over two-wheel drive during cornering. By transmitting power through all four tires, the Forester is better able to maintain its intended path, allowing for stable and controlled cornering. In contrast, when gripping ability is restricted to just two tires in front-wheel drive (FWD) or rear-wheel drive (RWD) vehicles, lateral forces tend to make the vehicle either "understeer" or "oversteer", which can lead to instability.

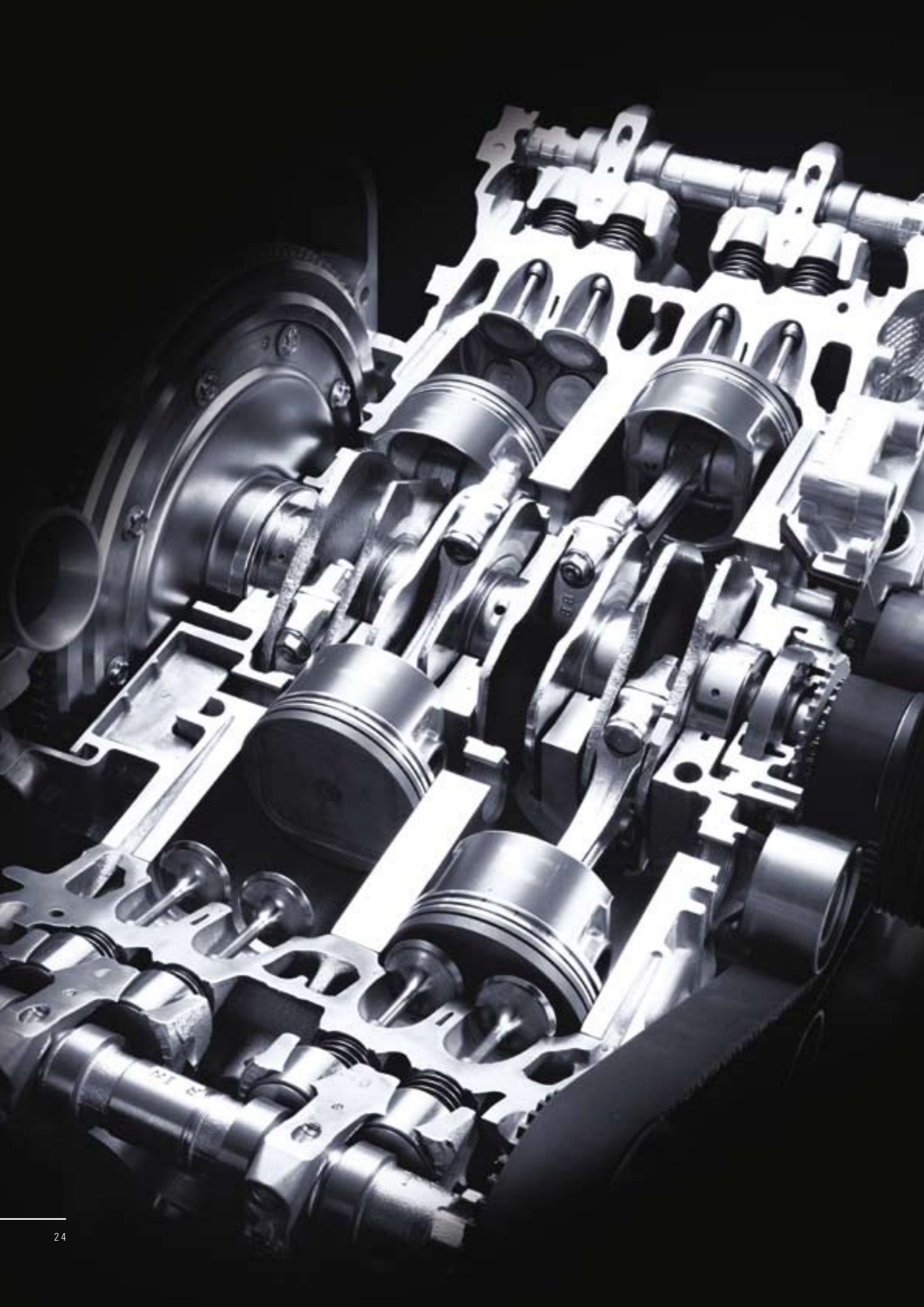

the POWER

ADVANCED ENGINE TECHNOLOGIES

Just like the engine in the mighty World Rally Championship (WRC) Impreza WRC2004, all Subaru vehicles sold in Canada are equipped with all-aluminum, horizontally-opposed SUBARU BOXER engines. This is because SUBARU BOXER engines are lightweight, compact and positioned to create a low centre of gravity. These attributes, along with the engine's responsiveness, efficiency and natural smoothness, help make the SUBARU BOXER the ideal focal point of the Subaru symmetrical full-time All-Wheel Drive system. Whether you choose the 2.5 litre naturally aspirated version or the 2.5 litre turbocharged version, both Forester engines offer a responsible balance between performance and efficiency.

2.5 litre turbo engine

Similar in basic design to the powerplant residing under the hood of the awesome Impreza WRX STi, the 2.5 litre, turbocharged SUBARU BOXER engine in the Forester 2.5XT is both incredibly potent and refined. Pumping out a class-leading 210 hp and 235 lb-ft of torque and boasting an Active Valve Control System (AVCS), the Forester 2.5XT's turbocharged and intercooled SUBARU BOXER engine is a lightweight, dual overhead cam (DOHC) unit that offers exhilarating, silky-smooth power delivery at the touch of the throttle. Also, thanks to the SUBARU BOXER's natural smoothness throughout the rev range, the Forester 2.5XT is equally at home on the highway or in the hustle and bustle of downtown traffic.



2.5 litre engine

The 2.5 litre single overhead cam (SOHC) naturally aspirated SUBARU BOXER engine that powers the Forester 2.5X and 2.5XS models is both free-revving and fuel efficient.

With its compact dimensions and light weight, the Forester's 2.5 litre, horizontally-opposed SUBARU BOXER helps to provide sedan-like handling and responsiveness with the low-end torque necessary to deal with a variety of driving conditions. Producing a healthy 165 hp and 166 lb-ft of torque, the naturally aspirated 2.5 litre engine achieves excellent fuel economy compared to most SUVs and impeccable reliability while remaining fun to drive no matter where your adventures take you.





the SHIFT

TRANSMISSION TECHNOLOGIES

Designed to take full advantage of the inherent virtues of Subaru full-time All-Wheel Drive and the symmetrical layout of the drivetrain, the manual and automatic transmissions in the 2005 Forester line-up are a marvel of engineering and efficiency. Created to bring smooth, vibration-free gear changes throughout the rev range and over a variety of road conditions, the Forester's transmissions are also cleverly packaged — as opposed to other vehicles featuring complex differentials and torque split systems. By combining the transmission, front differential and transfer case into a single unit that is mounted symmetrically along the centreline of the vehicle, Subaru engineers have created a transmission that is both compact and fuel efficient. Capable of delivering linear, controllable, full-time power to all four wheels in virtually any driving condition, the Forester's manual and automatic transmissions offer a superb balance of precise, smooth performance and engineered efficiency.

Electronically controlled 4-speed Automatic Transmission (4EAT)

The 2005 Forester's advanced, electronically controlled 4-speed automatic features a gated gear selector and smooth, seamless gearshifts. Working in combination with the latest generation electronically controlled multi-plate transfer clutch, the Forester's 4-speed automatic can intelligently distribute power between front and rear wheels to provide superior traction and control. For 2005, all 4-speed automatic Foresters feature direct shift control, which results in smoother gear changes and increased efficiency thanks to its low-friction design.



5-speed Manual Transmission (5MT)

The 5-speed manual transmission in the 2005 Forester is designed and engineered to integrate perfectly into the Forester's symmetrical full-time All-Wheel Drive system while offering unsurpassed smoothness, efficiency and driver friendliness. With a compact, viscous-coupling limited-slip centre differential which improves torque distribution, the 5-speed manual offers precise control and superior All-Wheel Drive traction. Also, a flexible flywheel and low-friction driven shaft bearings help to provide quiet, vibration-free operation. Driver friendliness comes in the form of Subaru's Hill Holder system, which helps to prevent the vehicle from rolling backwards after coming to a stop on an incline.



the DRIVABILITY

SUSPENSION TECHNOLOGIES

The balanced, symmetrical layout of the 2005 Forester's drivetrain provides a perfect foundation for 4-wheel independent suspension. Thanks to the compact size and the centrally mounted location of the SUBARU BOXER engine between the front struts, the Forester features long, equal-length axle shafts. These help to maximize suspension travel and balance at all four wheels, virtually eliminating "torque steer", which occurs when a vehicle pulls to one side under brisk acceleration. Beyond the inherent balance offered by front and rear equal-length axle shafts, the Forester's thoroughly tested and refined suspension, stabilizers and dampers work in unison to provide complete stability and smooth, sedan-like handling properties. By combining modern suspension technology with the benefits of the SUBARU BOXER engine and the balance of the symmetrical layout of the drivetrain, the Forester offers superb handling and poise — without the pitch-and-roll normally associated with sport-utility vehicles.

Suspension

Even the best All-Wheel Drive system in the world becomes ineffective if the tires are not making contact with the road. To ensure the utmost in safety and control, the 2005 Forester employs long-travel suspension as a part of the Subaru symmetrical full-time All-Wheel Drive system. Through the use of long-travel suspension, Subaru engineers were able to help the Forester's tires maintain contact with the road over uneven surfaces, helping to preserve vehicle stability when encountering potholes or rough terrain. Based on the same concepts used in our championship-winning WRC rally cars, the Forester's highly tuned suspension and rigid chassis improve stability, steering responsiveness and overall driving dynamics. Simply put, the Subaru symmetrical full-time All-Wheel Drive system's sophisticated suspension helps to keep the vehicle stable and the tires where they belong: on the road.

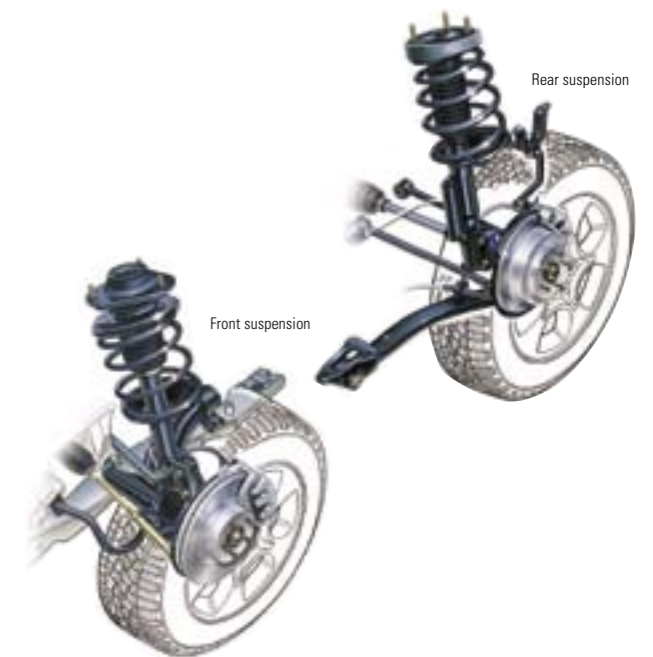

the ACTIVE safety

ACTIVE SAFETY TECHNOLOGIES

Safety starts with symmetrical full-time All-Wheel Drive

At Subaru, we believe a truly safe vehicle is one that excels at preventing accidents before they happen. With that in mind, the 2005 Forester was designed from the ground up to offer best-in-class active safety features in an effort to inspire driver confidence and peace of mind. Active safety begins with the Subaru symmetrical full-time All-Wheel Drive system, which offers sure-footed traction and control in a variety of road and weather conditions. From snow-covered back roads to rain-slicked highways, Forester drivers feel confident knowing that power can be directed to where it is needed most in virtually any situation. The Subaru symmetrical full-time All-Wheel Drive system also provides the Forester with the rock-solid stability to confidently carve through winding roads and sharp corners or blaze its own trail through rougher terrain. Because the Forester's All-Wheel Drive system is full-time, its benefits can be appreciated throughout every journey – even on dry, pristine roads.

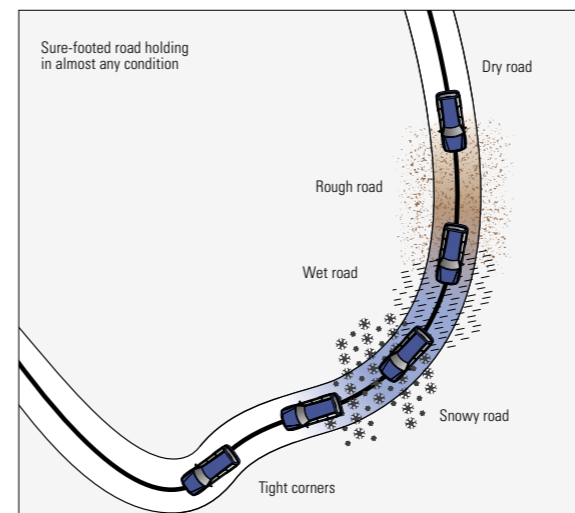

ABS braking

To compliment the active safety benefits of the Subaru symmetrical full-time AWD system, a 4-wheel / 4-channel / 4-sensor Anti-Lock Braking System (ABS) is

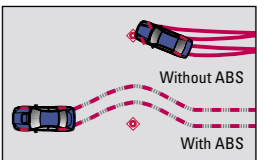

standard on all 2005 Forester models. Working through sensors at all four wheels, ABS prevents wheels from locking up during heavy braking, allowing the driver to apply the brakes and steer away from trouble at the same time. ABS provides outstanding safety and control, even during emergency manoeuvres or in inclement weather conditions.



Front ventilated disc brake



Rear disc brake

2.5XS and 2.5XT models are also equipped with Electronic Brake-Force Distribution (EBD), which controls the balance between front and rear brakes. By actively controlling the rear-wheel braking force, EBD helps to maintain a consistent stopping distance, even when the vehicle is weighed down with a full load.

Optimum visibility

Obstacles or hazards, including potholes, pedestrians, or even other motorists, are difficult to avoid if they can't be seen. That is why all 2005 Foresters offer excellent outward visibility, affording the driver a clear and unobstructed view of the road. Thanks to its high seating position and narrow pillars, the Forester boasts an impressive field of vision, making it easier to identify hazards and prevent accidents before they happen.

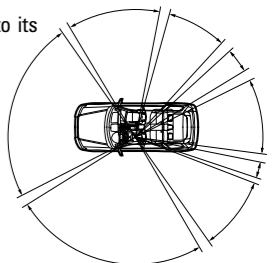

Superb outward visibility

the **PASSIVE** safety

PASSIVE SAFETY TECHNOLOGIES

Ring-shaped reinforcement frame

When an accident is unavoidable, Subaru's exceptional passive safety technologies help to offer a 360-degree barrier of protection. Thanks to the use of cutting-edge welding techniques, the Forester's ring-shaped reinforcement frame provides best-in-class collision safety for both driver and passengers while helping to reduce weight. The Forester also features energy-absorbing crumple zones and side-impact door beams, helping it to become the first compact SUV to earn the IIHS's highest possible rating† in three different crash tests.



■ : Ring-shaped reinforcement frame ■ : Sub-frame
■ : Chassis reinforcement frame

Pedestrian protection

Thanks to energy-absorbing front bumpers and innovative wipers that break away when subjected to enough force, the 2005 Forester not only protects its driver and occupants, but those outside the vehicle as well.



Break-away wipers

Aluminum hood

The Forester's aluminum hood is designed to minimize pedestrian injury in the event of a collision. Due to the distance between the energy-absorbing hood and the compact SUBARU BOXER engine, pedestrians are less likely to come into contact with the engine during a collision.



Aluminum hood

Airbags, seatbelts and passive safety head restraints

SRS dual-stage front airbags and SRS front side-impact airbags that help to protect against head and chest injuries during both front and side impacts are standard on all 2005 Forester models. In the event of a rear-end collision, both driver and front passenger seats feature passive safety head restraints, which move forward automatically to cradle the head and neck, lessening the risk of whiplash injuries. Front seatbelts feature pretensioners and load limiters, while a trio of three-point seatbelts and head restraints as well as an ISO-FIX/LATCH child seat anchor system are featured in the rear.

*SRS = Supplemental Restraint System
Most effective when used in conjunction with seatbelts.



SRS* dual-stage front airbags



SRS* front side-impact airbags



Three 3-point rear seatbelts



Passive safety head restraints

**INSURANCE INSTITUTE
FOR HIGHWAY SAFETY**

www.highwaysafety.org

† 2003 Forester rating of "Good" based on (6/03) 30 mph side-impact, (7/02) 40 mph frontal offset and (7/02) 5 mph bumper crash tests conducted by the Insurance Institute for Highway Safety (IIHS).

thinking responsibly

We want all Subaru owners to take pride in the fact that they are driving vehicles that are as environmentally friendly as we can possibly make them. Subaru is completely committed to environmental and energy issues, so we make every effort to reduce weight and improve vehicle aerodynamics, increasing fuel economy while reducing emissions to the lowest possible levels. We also develop recycling technologies that help to make efficient use of natural resources and cut down on waste. It is this kind of thinking and technology that will bring us all a better future.



2.5XT

the SPACE

FLEXIBLE SPACE



60/40-split-folding rear seats

Full flat cargo area

The capacity for everything.

Thanks to the 2005 Forester's symmetrical full-time All-Wheel Drive system and rugged nature, you can go just about anywhere. Thanks to its incredibly versatile interior and vast cargo space, you can take practically everything you need with you. With 60/40-split-folding rear seats that can fold down to reveal a flat, cavernous cargo area, roof rails, retractable cargo cover*, three 12V power outlets and clever, useful storage spaces throughout, the Forester is the perfect companion for your adventures.



The Forester offers impressive interior space all around, with generous width, headroom and rear legroom. Also, loading luggage through the tailgate to the cargo area is easy.

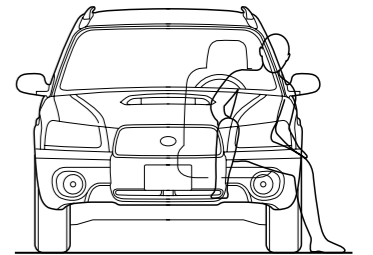

Thanks to the careful design of the seats and door openings, getting in and out of the Forester's spacious interior is simple.



60/40-split-folding rear seats

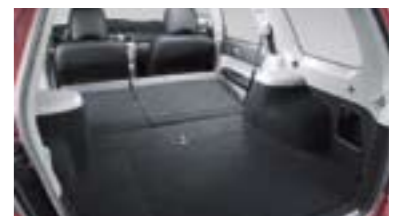

Full flat cargo area



Retractable cargo cover*
*standard on 2.5XT and all 2.5XS models

A higher quality cockpit.



One drive of the 2005 Forester and you'll feel immediately at home. With controls that are ergonomically designed and logically laid out, the Forester was designed with your driving pleasure in mind. Whether a quick trip to the corner store or a cross-country vacation, you'll feel in command and comfortable thanks to the Forester's high seating position and standard eight-way power adjustable driver's seat with lumbar support on all 2.5XS and 2.5XT models.

2.5XT

A higher quality of living.



The painstaking attention to detail that went into the design of the 2005 Forester will be appreciated by both driver and passengers. True quality and craftsmanship can be seen and felt in the textured design of the dash and interior trim, while thoughtful touches throughout the spacious cabin – such as a premium in-dash six-CD audio system and heated front seats in Forester 2.5XS and 2.5XT models – are bound to make every trip more enjoyable.

2.5XT



Forester 2.5X

While the 2005 Forester 2.5X is the entry model of the Forester line-up, it still boasts a wide array of comfort, convenience and safety features, including: Subaru symmetrical full-time All-Wheel Drive system; AM/FM/CD audio system; ABS; front and side-impact SRS airbags; 16" wheels; air conditioning; fog lamps; cruise control, 12V outlets (3); roof rails; power windows and locks with keyless entry; heated mirrors; passive safety head restraints; 60/40-split-folding rear seats; six-way adjustable driver's seat with lumbar support; and light grey woven cloth interior.



2.5X

Forester 2.5XS

Over and above the features offered on the Forester 2.5X model, the 2005 Forester 2.5XS offers a wide array of standard features to satisfy all your needs and wants, including: 16" aluminum alloy wheels; roof rack system; in-dash six-CD audio system; eight-way power adjustable driver's seat; leather-wrapped controls; ABS with EBD; limited-slip rear differential; heated front seats; retractable cargo cover; cargo tray; steel grey metallic bumpers and protective body-side cladding; and premium light grey cloth interior.



2.5XS



Forester 2.5XS Premium

On top of the standard features offered in the Forester 2.5X, the 2005 Forester 2.5XS Premium offers a refined balance of adventurous versatility and upscale good looks. Standard features include: in-dash six-CD audio system with six speakers; eight-way power adjustable driver's seat; ABS with EBD; 16" aluminum alloy wheels; leather-wrapped controls; limited-slip rear differential; heated front seats; roof rack system; monotone body colour; premium light grey cloth interior or optional grey leather (4EAT only); and a power glass moonroof.



2.5XS Premium

Forester 2.5XT

Beyond the turbocharged engine and standard features available on the Forester 2.5X model, the 2005 Forester 2.5XT includes: in-dash six-CD audio system with six speakers and subwoofer; engine immobilizer; roof rack system; spoiler; heated front seats; eight-way power adjustable driver's seat; 12-spoke aluminum alloy wheels; power glass moonroof; limited-slip rear differential; performance exhaust; ABS with EBD; monotone body colour; and exclusive off-black cloth interior and optional black leather that makes owning a 2.5XT a truly remarkable experience.



Best New SUV[†]
Car of the Year Awards
Presented by the Automobile Journalists
Association of Canada (AJAC)



2.5XT

Car and Driver's
Best Small SUV[†]
0-60 mph in just 5.3* seconds
*caranddriver.com

[†]2004 model year.

the SPECIFICATIONS

Engine

	Forester 2.5X, 2.5XS, 2.5XS Premium
Type	2.5L Single Overhead Cam (SOHC), 16 valve, horizontally-opposed, 4-cylinder boxer engine, electronic throttle control
Power	165 hp @ 5,600 rpm
Torque	166 lb-ft @ 4,000 rpm

	Forester 2.5XT
Type	2.5L Dual Overhead Cam (DOHC), 16 valve, horizontally-opposed, 4-cylinder boxer engine with turbocharger and intercooler, electronic throttle control and Active Valve Control System (AVCS)
Power	210 hp @ 5,600 rpm
Torque	235 lb-ft @ 3,600 rpm

Meets Low Emission Vehicle (LEV) standards (all Forester engines)

Transmission and Drivetrain

Manual Transmission	5-speed manual transmission (5MT) with Hill Holder system, standard (excluding 2.5XS Premium with leather) AWD type: Viscous-coupling limited-slip centre differential
---------------------	---

Automatic Transmission	4-speed electronic direct control automatic transmission (4EAT), standard (2.5XS Premium with leather), optional (all other models) AWD type: Electronically controlled multi-plate transfer clutch
------------------------	--

Drivetrain	Subaru symmetrical full-time All-Wheel Drive system Limited slip rear differential (viscous type), standard (2.5XS, 2.5XS Premium, 2.5XT)
------------	---

Chassis

Suspension	4-wheel fully-independent Heavy-duty raised
------------	---

Brakes	Power-assisted, dual-diagonal system ABS 4-channel/4-sensor/4-wheel Electronic Brake-Force Distribution (EBD) (2.5XS, 2.5XS Premium, 2.5XT) Front: Ventilated discs (294 x 24 mm), twin piston calipers Rear: Solid discs (266 x 10 mm), single piston calipers (2.5XS, 2.5XS Premium, 2.5XT); drums (229 mm) (2.5X)
--------	--

Steering	Engine speed sensitive, power-assisted rack and pinion 10.6 minimum turning circle (curb-to-curb)
----------	---

Measurements

	2.5X	2.5XS	2.5XS Premium	2.5XT
Fuel economy: Manual transmission (City/Hwy) (L/100km)	10.4/7.3	10.4/7.3	10.4/7.3	12.2/9.0
Fuel economy: Automatic transmission (City/Hwy) (L/100km)	10.4/7.6	10.4/7.6	10.4/7.6	11.7/9.3
Recommended minimum octane (AKI)	87	87	87	91
Fuel tank capacity (L)	60	60	60	60
Curb weight: Manual transmission (kg) (with leather*)	1400	1410	1425	1480/1485*
Curb weight: Automatic transmission (kg) (with leather*)	1420	1430	1445/1450*	1500/1505*
Gross Vehicle Weight Rating (GVWR) (kg)	1880	1880	1880	1960
Towing capacity: Maximum weight (kg) with trailer brakes (5MT) [†]	1087	1087	1087	1087
Towing capacity: Maximum weight (kg) with trailer brakes (4EAT) [†]	906	906	906	906
Towing capacity: Maximum weight (kg) without trailer brakes [†]	453	453	453	453
Length (mm)	4450	4450	4450	4450
Width (mm) with mirrors	2006	2006	2006	2006
Height (mm) with roof rails	1590	1590	1590	1585
Wheelbase (mm)	2525	2525	2525	2525
Track: Front/Rear (mm)	1495/1485	1495/1485	1495/1485	1495/1485
Minimum ground clearance (at curb weight) (mm)	190	190	190	195
Headroom: Front/Rear (mm)	1012/1010	1012/1010	992/939	992/939
Legroom: Front/Rear (mm)	1108/856	1108/856	1108/856	1108/856
EPA interior volume (L)	3554	3554	3421	3421
Cargo area: EPA volume (seats up) (L)	906	906	838	838
Cargo area: SAE volume (seats folded flat) (L)	1815	1815	1775	1775
Roof Rack System: Maximum load (kg)	68	68	68	68

[†]See owner's manual for detailed towing instructions



Safety and Security

• • • •	Airbags (SRS): Driver and front passenger, dual stage deployment
• • • •	Airbags (SRS): Front seat side-impact with head and chest protection
• • • •	Brake pedal: Collapsible, passive safety type
• • • •	Child safety: Rear door locking system
• • • •	Child safety: Rear seat ISO-FIX/LATCH anchor system
• • • •	Head restraints (front): Height adjustable, passive safety type
• • • •	Head restraints (rear): Removable and adjustable
• • • •	Seatbelts (front): 3-point with pretensioners and load limiters (ELR)
• • • •	Seatbelts (front): Height adjustable shoulder belt anchors
• • • •	Seatbelts (rear): 3-point, all seating positions (ALR/ELR)
• • • •	Seatbelts (rear): Height adjustable outboard shoulder belt anchors
◦ ◦ ◦ ◦	Security: Anti-theft system (pre-wired)
• • • •	Security: Keyless entry system with panic alarm
- - - •	Security: Engine immobilizer system
• • • •	Steering column: Collapsible
• • • •	Structure: Ring-shaped reinforcement frame
• • • •	Structure: Hydroformed front subframe
• • • •	Structure: Dual, side-impact door beams (front & rear)
• • • •	Structure: Energy absorbing crumple zones (front & rear)

Seating and Trim

• • • •	Accents/trim: Silver metallic finish
• • • •	Floor mats: "Forester" embroidered
• - - -	Interior: Flat woven cloth upholstery
- • • •	Interior: Moquette cloth upholstery
- - ◦ ◦	Interior: Leather upholstery and interior trim*
5 5 5 5	Seating: Capacity
• - - -	Seat (driver's): Height adjustable, ratchet lever type
- • • •	Seats (driver's): 8-way power adjustable with lumbar support
• - - -	Seats (driver's): 6-way manual adjustable with lumbar support
- • • •	Seats (front): Heated with high/low setting
• • • •	Seats (front): Sport type
• • • •	Seats (rear): 60/40-split, flat folding

Audio

• - - -	AM/FM/Weather Band/CD
- • • •	AM/FM/Weather Band/6CD Premium audio system
• • • •	Antenna: In-glass integrated
4 4 4 4	Speakers (main)
◦ ◦ 2 2	Speakers: Door tweeters
◦ ◦ ◦ •	Speakers: Subwoofer

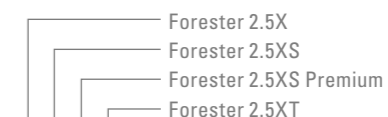

Exterior

• • • •	Body: Anti-corrosion treatment
• • • •	Body: Dual-sided galvanized steel
• - - -	Bumpers & protective bodyside cladding (Textured Grey)
- - - -	Bumpers & protective bodyside cladding (Steel Grey Metallic)
- - • •	Bumpers & protective bodyside cladding (body colour)
- • • •	Bumper (rear): Step pad
• - - -	Door mirrors: Power adjustable, foldable & heated (black)
- • • •	Door mirrors: Power adjustable, foldable & heated (Metallic Grey)
- - - •	Door sills: Aluminum
• • • -	Doors: 4, black handles
- - - •	Doors: 4, body colour handles
• • • •	Fog lights: Multi-reflector halogen
• • • •	Headlights: Auto-off with ignition switch
• • • •	Headlights: Contoured multi-reflector halogen
• • • •	Hood: Aluminum alloy
- - - •	Hood: Functional hood scoop for intercooler air flow
- - • •	Moonroof: Large glass, power tilting and sliding with sunshade
• • • -	Roof Rack System: Roof rails (black)
- - - •	Roof Rack System: Roof rails (aluminum finish), body colour end mounts
◦ • • •	Roof Rack System: Cross bars (lockable)
◦ • • •	Splash guards
◦ ◦ ◦ •	Spoiler: Roof line
• • • •	Tire (spare): Full size (under cargo area)
• • • •	Tires: 215/60 R16 94H Yokohama Geolandar G900
• - - -	Wheels: 16" X 6.5" styled steel
- • • -	Wheels: 16" X 6.5" aluminum alloy, 8-spoke Forester design
- - - •	Wheels: 16" X 6.5" aluminum alloy, 12-spoke Turbo Forester design
• • • •	Windows: Tinted
• • • •	Windshield: Laminated and tinted
• • • •	Window (rear): Defogger with timer
- • • •	Wipers (windshield): Heated glass de-icer
• • • •	Wipers (windshield): Variable intermittent with washer
• • • •	Wiper (rear window): Intermittent and continuous mode with washer
• • • •	Wiper (rear window): De-icer heater

- standard
- accessory
- not available

*2.5XS Premium with leather only available in automatic transmission.



Controls

- • • • Climate control: Air conditioning
- • • • Climate control: Automatic with seven speed fan
- • • • Climate control: Air filtration system
- • • • Cruise control: Steering wheel controls
- - - - Gear selector: Soft-grip
- • • • Gear selector: Leather-wrapped
- - - - Parking brake: Soft-grip
- • • • Parking brake: Leather-wrapped
- • • • Pedal: Driver's foot rest
- - - - Steering wheel: Soft-grip, 3-spoke design
- • • • Steering wheel: Leather-wrapped, 3-spoke design
- • • • Steering wheel: Tilt adjustable

Instruments

- • • • Clock: Digital back-lit LCD in dash
- • • • Gauges: Analog with red illuminated needles
- • • • Gauges: Silver trim
- - - • Gauges: Sport design
- • • • Instrument panel: Automatic transmission gear position indicator (4EAT)
- • • • Instrument panel: Coolant temperature gauge
- • • • Instrument panel: Fuel gauge with low fuel warning light
- • • • Instrument panel: Outside temperature display
- • • • Odometer: Digital, dual trip modes
- • • • Speedometer: Electronically controlled analog
- • • • Tachometer
- • • • Warning lights: ABS, airbag, brake fluid, oil pressure, check engine, door ajar warning

Cargo Area

- • • • Cargo tray/protective mat
- • • • Cargo tie down hooks
- • • • Grocery bag hooks
- • • • Light: Cargo area
- • • • Power outlet: 12V in cargo area
- • • • Retractable cargo cover
- • • • Storage: Sub-floor tray

Warranties

3 years / 60,000 km "bumper to bumper" no deductible limited warranty

5 years / 100,000 km major components and powertrain

3 years / unlimited km CAA roadside assistance

See warranty book for details and limitations.



Convenience

- • • • Armrest (front): With console storage
- ◦ ◦ ◦ Armrest (front): Extension with storage
- • • • Cup holders (front): Console integrated
- • • • Cup holders (rear): Retractable
- • • • Door locks: Power, remote keyless entry
- • • • Glove box: Lockable
- • • • Ignition key ring: Illuminated
- • • • Light: Interior dome with off delay
- • • • Light: Map spotlights
- • • • Power outlet: 12V in armrest console and in dash
- • • • Storage: Coin box
- • • • Storage: Front door storage compartments
- • • • Storage: Dash compartment, lidded
- • • • Storage: Overhead compartment
- • • • Visor (sun): Centre windshield
- • • • Visor: Dual, with mirrors
- • • • Windows (power): Driver's window auto down

Colours

- G - G B Aspen White
 - G - G B Cayenne Red Pearl
 - G G G B Champagne Gold Opal
 - G - - B Crystal Grey Metallic
 - G G B Obsidian Black Pearl
 - G G G B Platinum Silver Metallic
 - G G G B Regal Blue Pearl
 - G G - - Woodland Green Pearl
- G Grey Interior B Black Interior - not available*

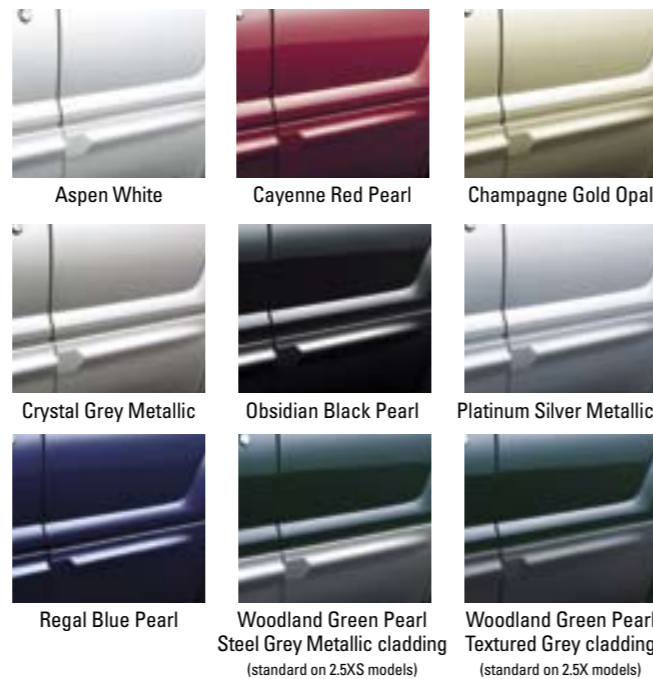

- standard
- accessory
- not available



Great journeys begin in a Subaru. Enjoy.