



REAR ROOF SPOILER
PART No. E7210FL100
IMPREZA 5D (17MY~)
XV, CROSSTREK (18MY~)

INSTALLATION
INSTRUCTION

KIT CONTENTS:

①

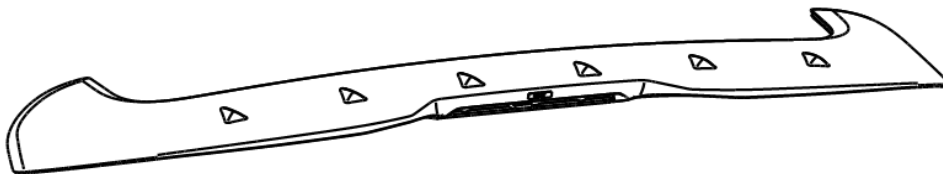

× 1

TOOLS REQUIRED:

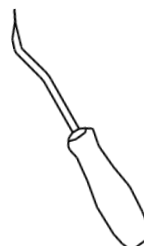
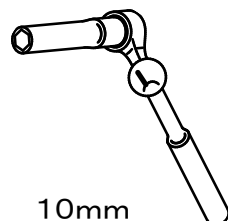
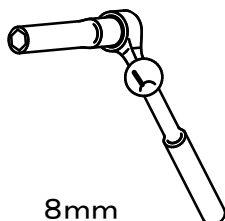
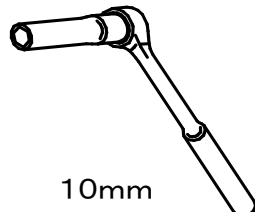
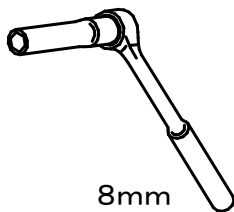

1

Note:
Disconnect the negative cable from battery.

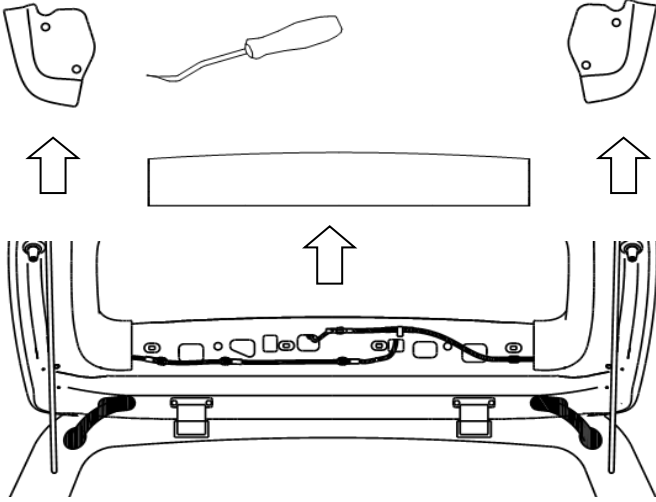

2

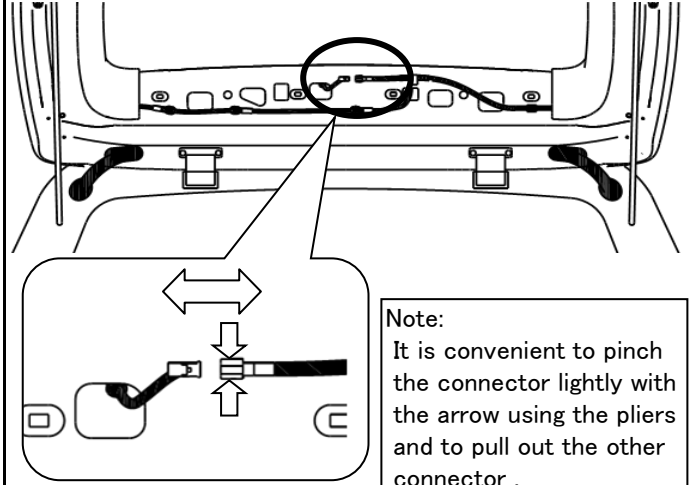

Note:
It is convenient to pinch the connector lightly with the arrow using the pliers and to pull out the other connector .

3

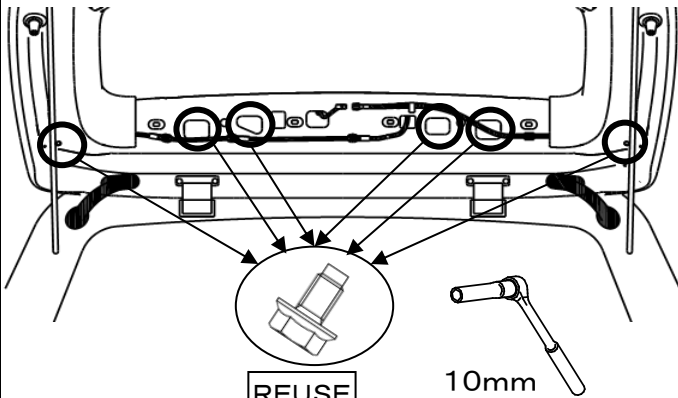

REUSE 10mm

Note:
Do not drop the nut into the trunk lid.

4

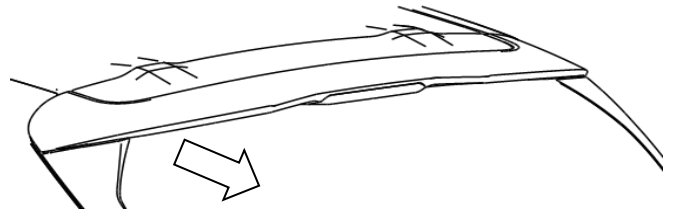

Note:
Do not get a finger stuck in the rear gate.

5

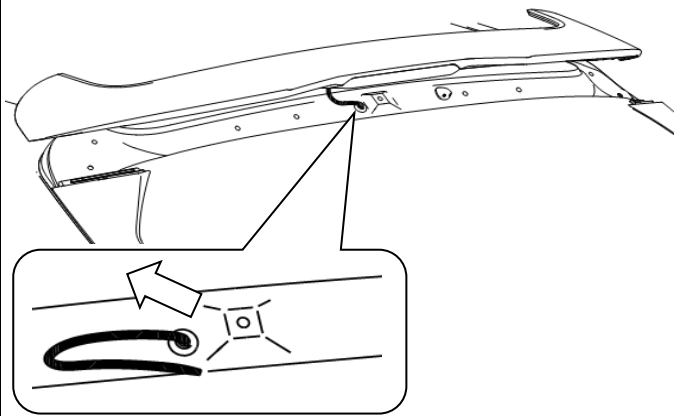

6

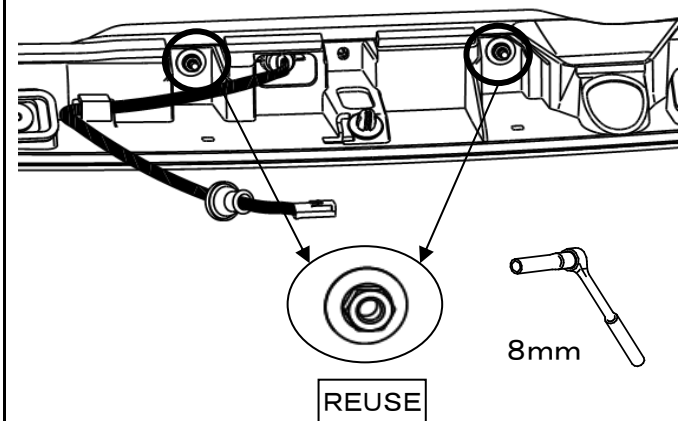

REUSE 8mm

7

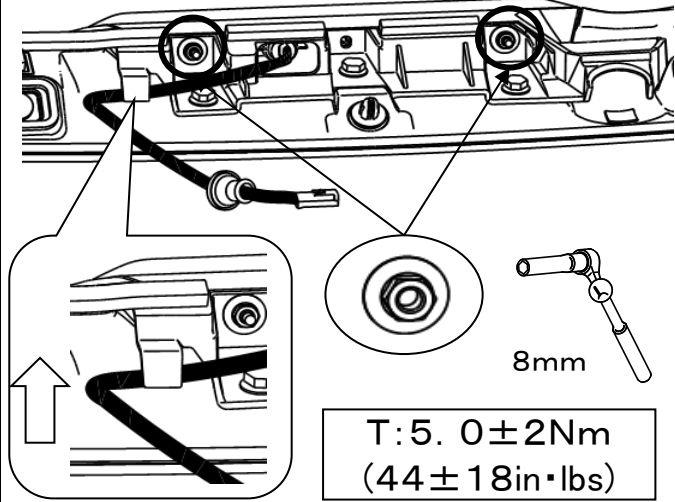

8

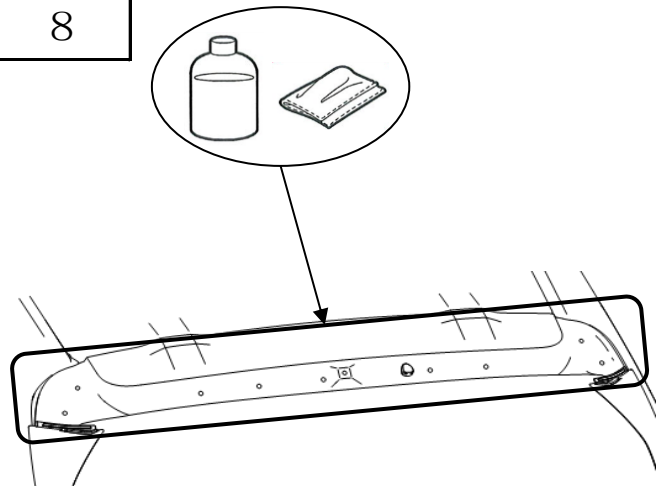

9

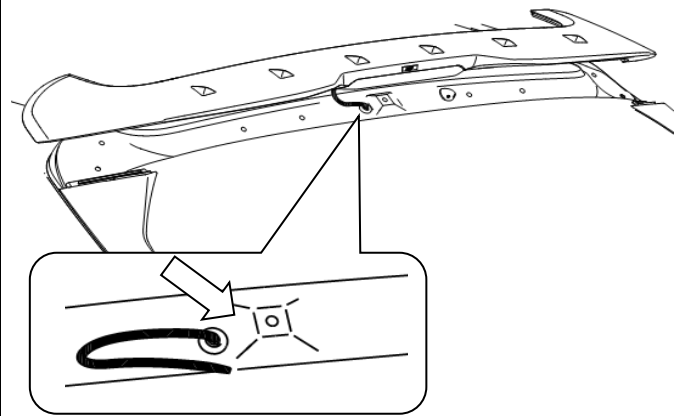

10

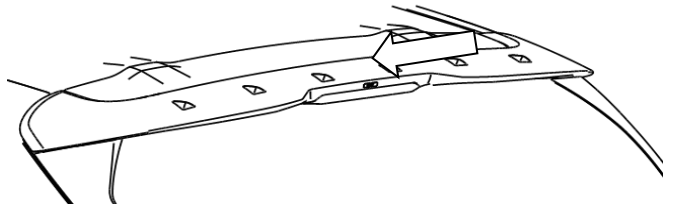

Note:
Push it to the vertical direction of the clip.

11

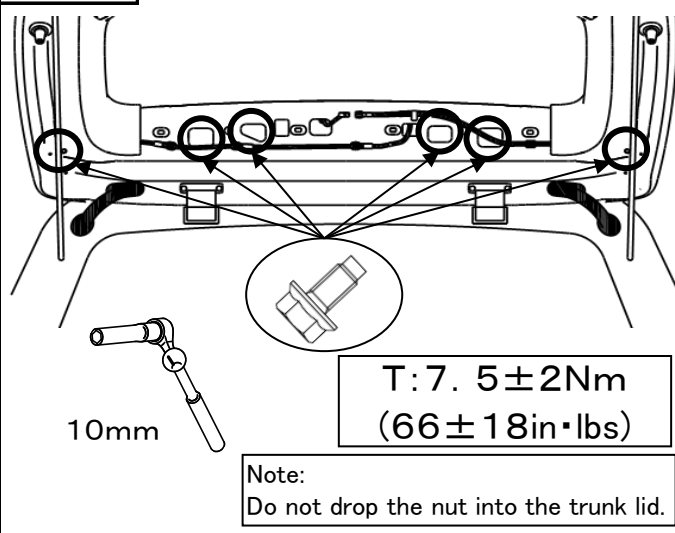

12

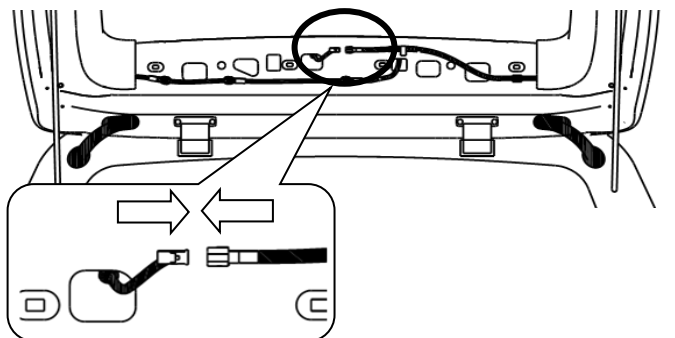

Note:
After reconnecting the connector, reconnect battery, please check the lighting of the lamp before step 13.

1 3

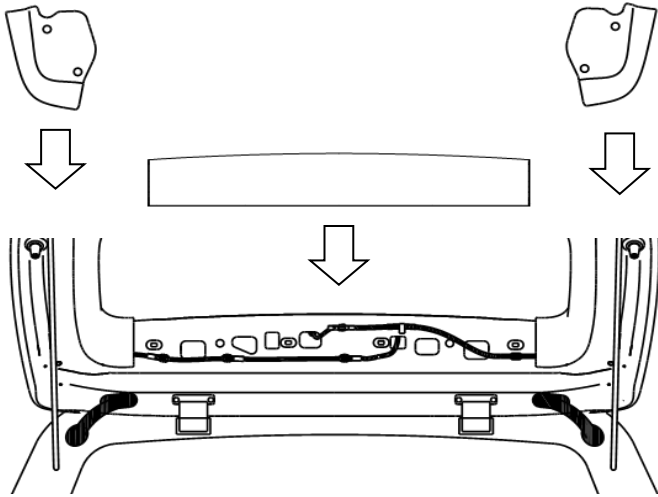

1 4

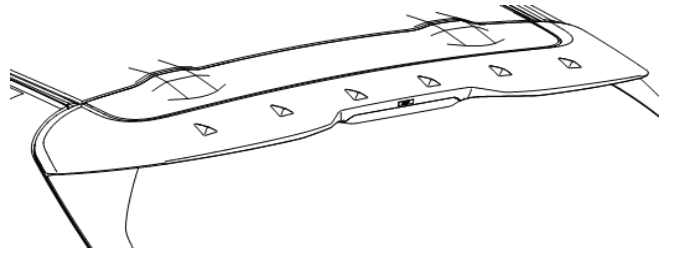



AILERON DE TOIT ARRIÈRE NO DE PIÈCE E7210FL100

IMPREZA 5 P. (2017~)
XV, CROSSTREK (2018~)

INSTRUCTIONS
D'INSTALLATION

CONTENU DE LA TROUSSE :

①

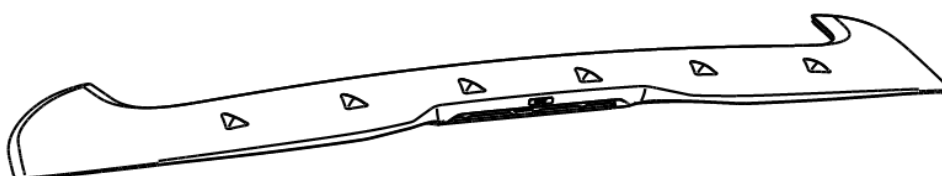

× 1

OUTILS REQUIS :

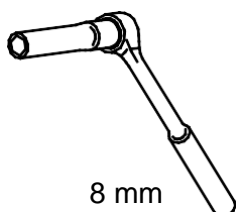

8 mm

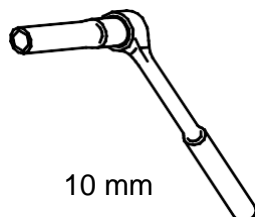

10 mm

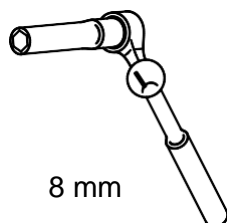

8 mm

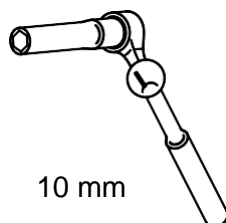

10 mm

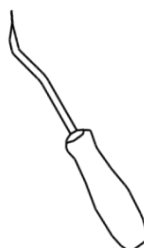

1

Remarque :
Débrancher le câble négatif de la batterie.

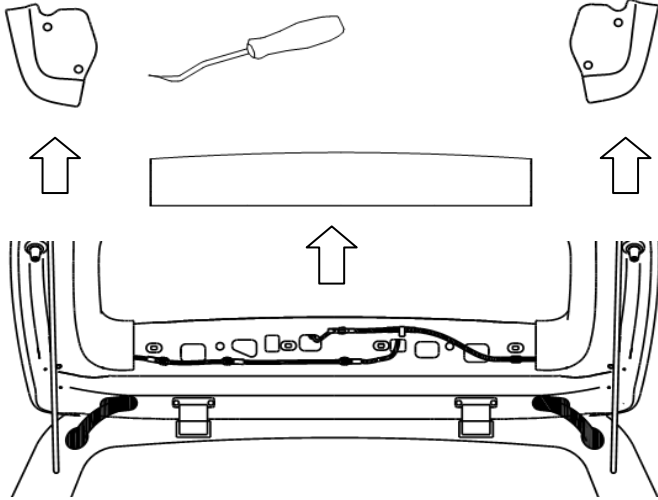

2

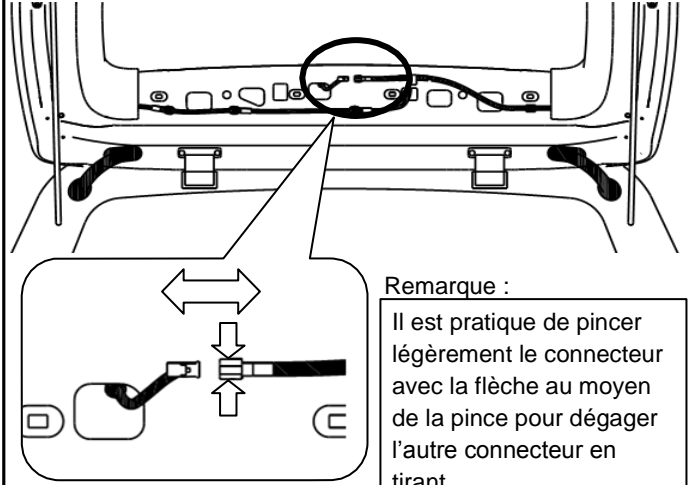

Remarque :
Il est pratique de pincer légèrement le connecteur avec la flèche au moyen de la pince pour dégager l'autre connecteur en tirant.

3

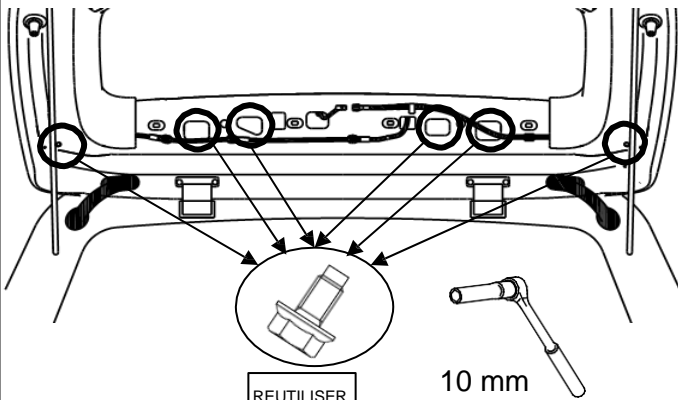

Remarque : Prendre garde de ne pas échapper l'écrou dans le couvercle du coffre.

4

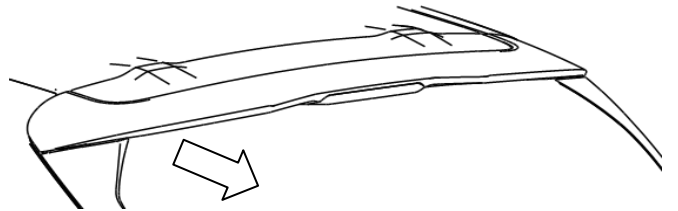

Remarque : Prendre garde de ne pas se coincer un doigt dans le hayon arrière.

5

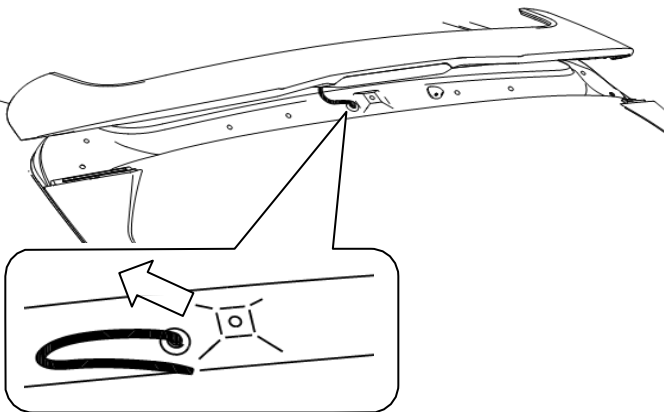

6

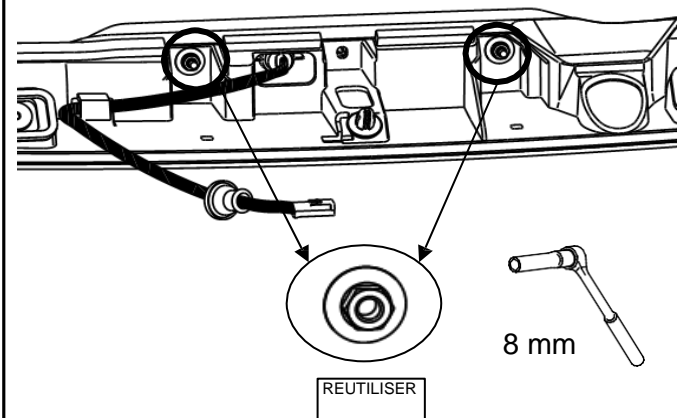

7

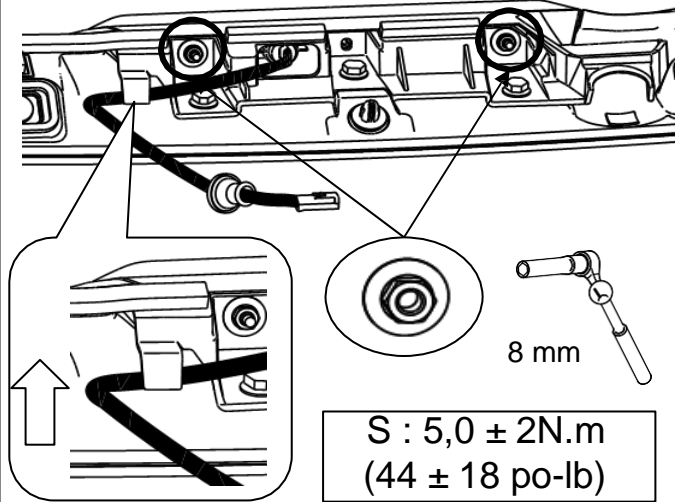

S : 5,0 ± 2N.m
(44 ± 18 po-lb)

8

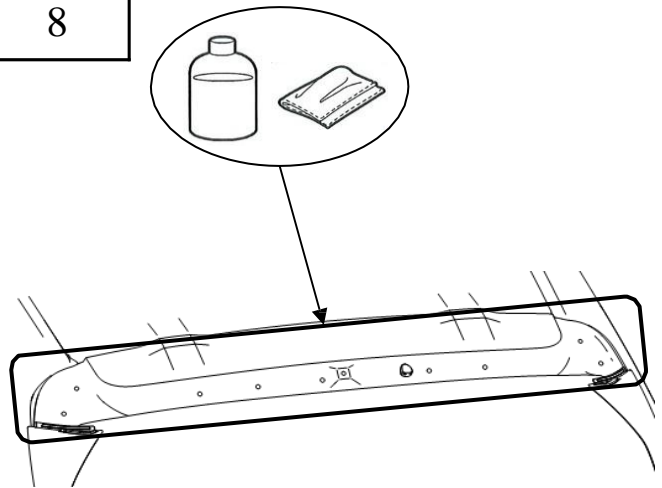

9

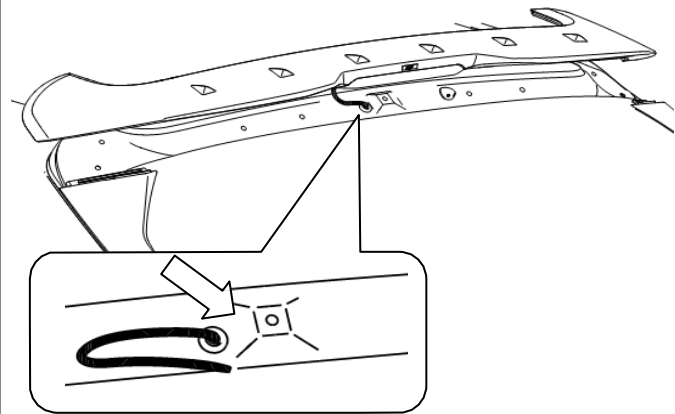

10

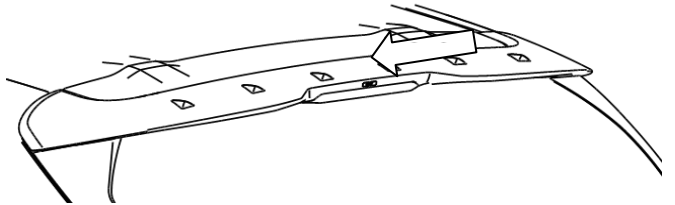

Remarque :
Le pousser à la verticale sur l'agrafe.

11

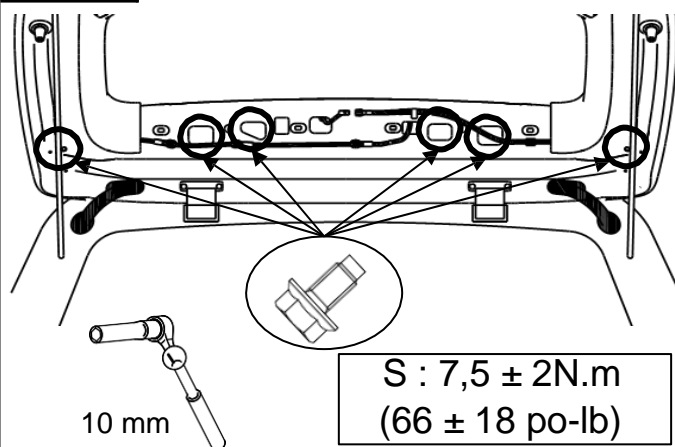

10 mm

S : 7,5 ± 2N.m
(66 ± 18 po-lb)

Remarque : Prendre garde de ne pas
échapper l'écrou dans le couvercle du coffre.

12

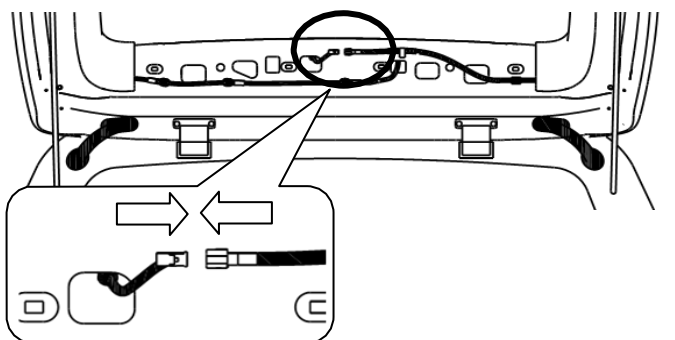

Remarque : Après le raccordement du connecteur,
rebrancher la batterie et vérifier l'éclairage de la lampe
avant de passer à l'étape 13.

13

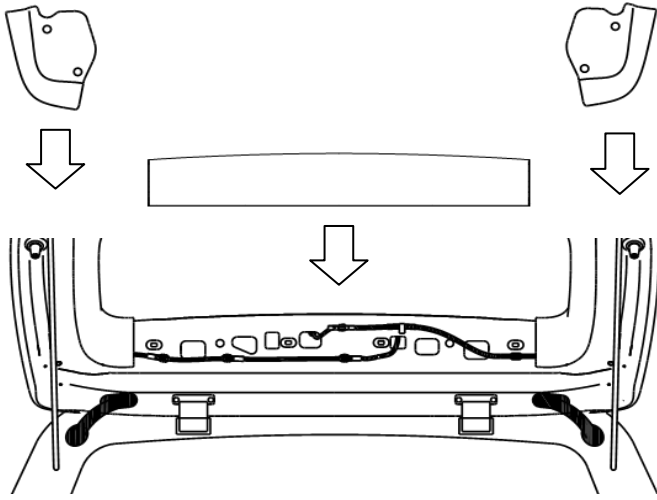

14

